

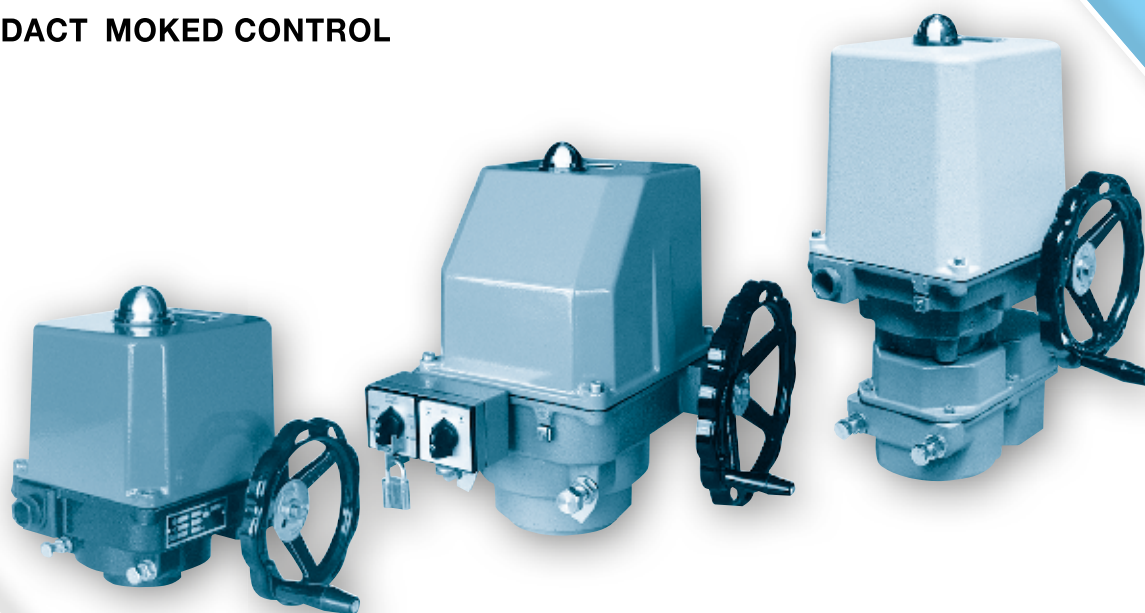

MODACT MOKED 63 T.No. 52 325  
MOKED 125 T.No. 52 326  
MOKED 250 T.No. 52 327  
MOKED 500 T.No. 52 328  
MOKED 1000 T.No. 52 329

MODACT MOKED CONTROL



**MOUNTING INSTRUCTIONS**

**Electric Part-turn (90°) Actuators  
for Ball and Flap Valves**

**MODACT MOKED**

**Type numbers 52 325 - 52 329**

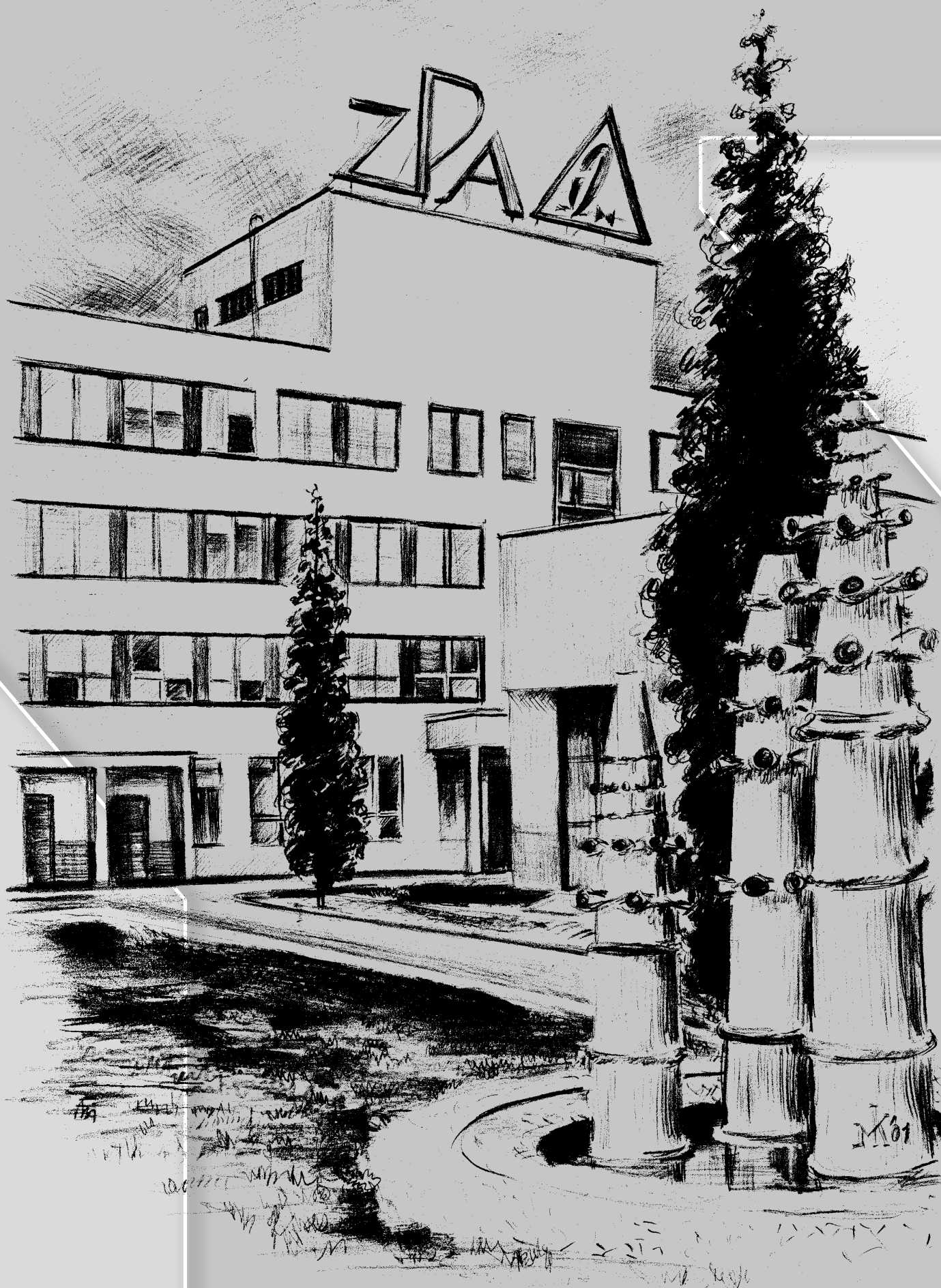

ZPA Pečky, a.s. is certified company in accordance with ISO 9001 as amended.

# CONTENS

1. Application .....	3
2. Operating conditions; Operating position .....	3
3. Operation Mode, Service life of actuators .....	4
4. Technical data .....	5
5. Actuator outfit .....	6
6. Electric parameters .....	6
7. Electronic outfit .....	7
7.1 DMS2 ED .....	7
7.2 Procedure of setting parameters by means of push-buttons .....	9
7.3 Procedure of setting parameters by program DMS2 .....	11
7.4 Autodiagnosics .....	12
7.5 Restoring parameters from backup .....	12
7.6 DMS2 .....	19
7.7 Procedure of setting parameters by program DMS2 .....	19
Table – basic parameters .....	29–32
Dimensional sketch of electric actuators MODACT MOKED .....	32–36
8. Assembly and putting actuator into operation .....	37
9. Operation and maintenance of actuators .....	37
Spare parts .....	38

## 1. APPLICATION

The actuators **MODACT MOKED** are designed for shifting control elements by a reversible rotary motion with the turning angle of the output part 90°, including cases when tight closure in end positions is required. Typical example of using is control of ball and flap valves in similar installations in the regime of remote control as well as automatic regulation. The electric actuators **MODACT MOKED** are mounted directly on the controlled element.

## 2. OPERATING CONDITIONS, OPERATING POSITION

### Operating conditions

The actuators **MODACT MOKED** are resistant against effect of operating conditions and external effects of classes AC1, AD5, AD7, AE5, AE6, AF2, AG2, AH2, AK2, AL2, AM-2-2, AN2, AP3, BA4 and BC3 according to ČSN 33 2000-5-51 ed. 3.

When the actuator is installed on a free area it is recommended to fit it with a light shelter against direct impact of atmospheric effects. The shelter should overlap the actuator contour by at least 10 cm at the height of 20 – 30 cm.

When actuators are to be installed in the working environment with temperature below +10 °C and in the environment with relative humidity above 80 %, it is always necessary to use an anti-condensation heater fitted to the actuator.

The electric actuators can be installed in areas with non-flammable and non-conductive dust, provided that this does not adversely influence their function. Here, it is necessary to strictly observe ČSN 34 3205. It is recommended to remove dust as soon as its layer is about 1 mm thick.

#### Notes:

*The area under a shelter means the one where falling of atmospheric precipitations under and angle up to 60° from the vertical is prevented.*

*The electric actuator must be installed in a place where cooling air has a free access. Minimum distance from a wall for access of air is 40 mm. Therefore, the area where the electric actuator is installed must be sufficiently large, clean and ventilated.*

### Surrounding temperature

Operating temperature for the **MODACT MOKED** is from -40 °C to +60 °C.

### Classes of external effects – excerpt from ČSN 33 2000-5-51 ed. 3.

#### Class:

- 1) AC1 – elevation above sea level ≤ 2000 m
- 2) AD5 – spouting water; water can spout in any direction
- AD7 – water occurrence – shallow dipping

- 3) AE5 – medium dustiness  
AE6 – strong dustiness
- 4) AF2 – occurrence of corrosive or polluting substances from atmosphere. Presence of corrosive polluting substances is significant.
- 5) AG2 – medium mechanical stress by impacts – common industrial processes
- 6) AH2 – medium mechanical stress by vibrations – common industrial processes
- 7) AK2 – serious risk of growth of vegetation and moulds
- 8) AL2 – serious danger of the occurrence of animals (*insects, birds, small animals*)
- 9) AM-2-2 – normal level of the signal voltage. No additional requirements
- 10) AN2 – medium solar radiation with intensities  $> 500 \text{ W/m}^2$  and  $\leq 700 \text{ W/m}^2$
- 11) AP3 – medium seismic effects; acceleration  $> 300 \text{ Gal}$   $\leq 600 \text{ Gal}$
- 12) BA4 – personal abilities. Instructed people.
- 13) BC3 – frequent contact with the earth potential. Persons coming frequently into contact with “live” parts or standing on a conducting base.

Actuator are not intended for use in residential environments and may not secure an adequate protection of receiving a radio signal in these environments.

## Corrosion protection

Actuators are standardly delivered with surface treatment corresponding to category of corrosion aggressiveness C1, C2 and C3 according to ČSN EN ISO 12944-2.

On customer's request is possible to do surface treatment corresponding to category of corrosion aggressiveness C4, C5-I and C5-M.

In following table is provided an overview of environment for each categories of corrosion aggressiveness according to ČSN EN ISO 12944-2.

Corrosion aggressiveness level	Example of typical environment	
	Outdoor	Indoor
<b>C1</b> (very low)		Heated buildings with clean atmosphere e.g. offices, shops, schools, hotels.
<b>C2</b> (low)	Atmosphere with low level of pollution. Mostly outdoor areas.	Unheated buildings, in which may occur condensation, e.g. stocks, sports halls.
<b>C3</b> (middle)	Urban industrial atmospheres, mild pollution of sulfur dioxide. Seaside areas with middle salinity.	Production areas with high humidity and low air pollution, e.g. food industry, processing factories, breweries.
<b>C4</b> (high)	Industrial areas and seaside areas with middle salinity.	Chemical plants, swimming pools, seaside shipyard.
<b>C5-I</b> (very high – industrial)	Industrial areas with high humidity and aggressive atmosphere.	Buildings or areas with predominantly continuous condensation and high air pollution.
<b>C5-M</b> (very high – seaside)	Seaside areas with high salinity.	Buildings or areas with predominantly continuous condensation and high air pollution.

## Operating position

The actuators can be operated in any operating position.

## 3. OPERATION MODE, SERVICE LIFE OF ACTUATORS

### Operation mode

The actuators can be operated with the type of loading S2 according to ČSN EN 60 034-1. The run period at temperature  $+50 \text{ }^\circ\text{C}$  is 10 minutes; the mean value of loading torque should not exceed 60 % of the value of maximum tripping torque  $M_V$ . The actuators can also work in the regime S4 (*interrupted run with start-up*) according to ČSN EN 60 034-1. Load factor  $N/N+R$  is max. 25 %; the longest working cycle ( $N+R$ ) is 10 minutes (*course of working cycle is shown in the figure*). The highest number of closing operations in automatic regulation is 1200 cycles per hour. Mean value of loading torque with load factor 25 % and surrounding temperature  $+50 \text{ }^\circ\text{C}$  is not higher than 40 % of maximum tripping torque  $M_V$ .

The highest mean value of loading torque is equal to rated torque of the actuator.

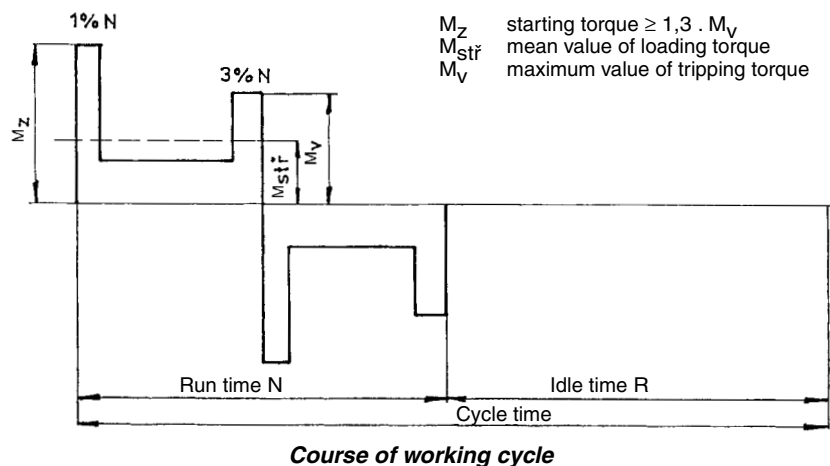

## Service life of actuators

The actuator intended for shut-off valves must be able to perform at least 10,000 operating cycles (*C - O - C*).

The actuator intended for regulating purposes must be able to perform at least 1 million cycles with operation time (*during which the output shaft is moving*) at least 250 hours. Service life in operating hours (*h*) depends on load and number of switching. Not always, high frequency of switching influences positively accuracy of regulation. For attaining the longest possible faultless period and service life, frequency of switching is recommended to be set to the lowest number of switching necessary for the given process. Orientation data of service life derived from the set regulation parameters are shown in the following table.

Service life of actuators for 1 million starts

Service life [h]	830	1 000	2 000	4 000
Number of starts [1/h]	Max. number of starts 1200	1 000	500	250

## 4. TECHNICAL DATA

### Supply voltage of electric motor:

According to Table 1

1 x 230 V, +10 %, -15 %, 50 Hz ±2 %  
 3 x 230/400V, +10 %, -15 %, 50 Hz ±2 %  
 (or as shown on the motor rating plate)

Other supply voltage for electric actuators should be discussed with the manufacturer.

### Protective enclosure

Protective enclosure of actuators: **MODACT MOKED** – IP 67 according to ČSN EN 60529.

### Noise

Level of acoustic pressure A max. 85 dB (A)  
 Level of acoustic output A max. 95 dB (A)

### Tripping torque

Tripping torque is set at the manufacturer according to the customer's requirements within the range given in Table No. 1. If setting of tripping torque is not required maximum tripping torque of the required type number of the electric actuator is set.

### Self-locking

The actuators are self-locking. Self-locking of the electric actuators is ensured by a mechanical or electromagnetic brake of the electric motor.

### Sense of rotation

When looking at the output shaft in the direction towards the control box, the CLOSE direction of rotation is identical with the clockwise sense.

### Working stroke

Rated working stroke of electric actuator is 90°.

### Manual control

Manual control is performed directly by a handwheel (*without clutch*). It can be used even when the electric motor is running (*the resulting motion of the output shaft is determined by the function of the differential gear*). When the

handwheel is rotated clockwise the output shaft of the actuator also rotates clockwise (*when looking at the shaft towards the control box*). On condition that the valve nut is provided with left-hand thread, the actuator closes the valve.

**Torque-limit switches in the actuator are set and work when the actuator is under voltage.**

**When using the manual control, ie. actuator is controlled mechanically, the torque-limit switches doesn't work and the valve can be damaged.**

## 5. ACTUATOR OUTFIT

### Position indicator

The actuator can be fitted with a display as an option for **DMS2 ED** electronic system. Actuator with **DMS2** electronic system is equipped with two-line display. **MOKED** actuator can be also fitted with a mechanical local position indicator.

### Anti-condensation heater

The actuators are fitted with an anti-condensation heater preventing condensation of water vapour. Connects to net with voltage of 230 V mains and is connected to a thermostat.

### Local control

The local control is used to control the actuator from the installation site.

Local control, when equipped with an actuator, consists of two switches. One chooses between LOCAL mode – 0 – REMOTE and the other between OPEN – STOP – CLOSE.

## 6. ELECTRIC PARAMETERS

### External electric connection

The terminal board of the actuator is fitted with terminals allowing one copper or aluminium conductor with a maximum cross-section of 2.5 mm<sup>2</sup> or two conductors with the same cross-sectional area up to 1 mm<sup>2</sup> to be connected.

Connecting of actuators with connector – on special request.

### Actuator internal wiring

The internal wiring diagrams of the **MODACT MOKED** actuators with terminal designation are shown in this Mounting and operating instructions.

Each actuator is provided with its internal wiring diagram on the inner side of the actuator cover. The terminals are marked on a self-adhesive label attached to a carrying strip under the terminal block.

### Isolation resistance

Isolation resistance of electric control circuits against the frame and against each other is min. 20 MΩ. After a dump test, isolation resistance of control circuits is min. 2 MΩ. See Technical specifications for more details.

### Overheating protection of electric motor

All electric motors have thermal fuses in their winding. They serve as an additional protection; they do not substitute the overcurrent protection or circuit breaking.

The fuses of single-phase electric motors are internally interconnected with the winding and, in case of overheating, they cut out the electric motor; after cooling down, they cut it in automatically.

The fuses of three-phase electric motors are separately led out and they can be connected into control or signalling circuits. They are connected to the actuator terminal board as a standard for MOKED 63 (*type no. 52 325*) only.

Load-bearing capacity is 250 V AC / 2.5 A.

### Electric strength of electric circuits isolation

Circuits of anti-condensation heater		1 500 V, 50 Hz
Electric motor	Un = 1 x 230 V	1 500 V, 50 Hz
	Un = 3 x 230/400 V	1 800 V, 50 Hz

### Deviations of basic parameters

Tripping torque	±15 % of max. tripping torque
Shifting time of output shaft	+10 % of rated value - 15 %
Setting of working stroke	±1°





**Realization:**

**Replacement of electric-mechanical board** the provided relay contacts substitute position, torque and signalling micro-switches; current feed-back signal 4 – 20 mA can also be brought out; the actuator is controlled by the superior control system with signals “*open*” and “*close*”.

**CONTROL** The electronics covers also function of the regulator; the output shaft position is controlled by analog input signal.

**Function and setting of output relays**

The output relays replace end-limit micro-switches; to some extent, function of the output relays differs according to chosen mode of electronics or it can be selected, preferably by the setting program.

**Relay MO, MZ, SO, SZ**

Relay	DMS2 ED	DMS2 ED Control
MO	<b>torque open</b> (also changes-over to errors)	<b>motor open</b>
MZ	<b>torque closed</b> (also changes-over to errors)	<b>motor close</b>
PO	<b>position open</b>	<b>torque open</b> (also changes-over to errors ) + optional tripping in position open (parameter Tripping)
PZ	<b>position closed</b>	<b>torque closed</b> (also changes-over to errors ) + optional tripping in position closed (parameter Tripping)

In the version Control, the **function of relay MO/MZ** is same as that of motor relays.

Their operation is controlled by:

- **regulation loop** (deviation of required and actual position)
- **active errors**

Any induced active error will change over both relays to a standstill position (*coils not energized*). In case of errors, the relays with a function of torque relays (*in both versions DMS2 ED and DMS2 ED Control*) are also controlled.

**Relays SZ, SO, READY**

Relay 3/SZ - <b>It usually signalizes position closed</b> , it can be changed-over to any offered signalization Relay 4/SO - <b>It usually signalizes position open</b> , it can be changed-over to any offered signalization	Relay <b>READY</b> - <b>It usually signalizes errors + warning + not remote</b> , it can be changed-over to any offered signalization
<div style="border: 1px solid black; padding: 5px;"> <b>Relé 3 / SZ Relé 4 / SO</b> </div> OFF position O position Z torque O torque Z torque + position O torque + position Z opening closing motion position negated position local control remote control control OFF torque O or Z motion - blinker	<div style="border: 1px solid black; padding: 5px;"> <b>Relé Ready</b> </div> vypnuto varování chyby varování nebo chyby chyby nebo není dálkové chyby nebo var. nebo není dál. moment O nebo Z
<b>Relay 3/SZ Relay 4/SO</b>  <b>For SO and SZ relays the following functions have been added:</b> <b>Moment O negated:</b> after reaching the set moment in the direction the relay will open. <b>Moment Z negated:</b> after reaching the set moment in the direction the relay closes. <b>Moment O or Z negated:</b> after reaching, build moment in direction closed or the relay will open.	<b>Ready Relay</b>  OFF warning errors warning or errors errors or no remote errors or warning or no remote torque O or Z



## Setting program

The setting program is same for communication with the electronics DMS2ED and DMS2. The users' version can be freely downloaded.

**Note:** In the window "Parameters" of the setting program, column "Access", the word "NO" designates parameters that cannot be changed by the user (change of these parameters is blocked).

Parametr	Změna	Chyba	Přístup	
Setrvačnost [0.1%]			NE	5
Setr. Doběh [0.1s]			NE	6
Necitlivost [%]				1

Parametr – Parameter  
 Změna – Change  
 Chyba – Error  
 Přístup – Access  
 Setrvačnost (0,1 %) – Inertia [0.1 %]  
 Setr. Doběh (0,1 s) – Inertial run-out [0.1 s]  
 Necitlivost (%) – Insensitivity [%]  
 NE – NO

## 7.2 PROCEDURE OF SETTING PARAMETERS BY MEANS OF PUSH-BUTTONS

For simple programming of required operating parameters, the control unit is fitted with four push-buttons: **MENU, P, O, C** and three signal lamps.

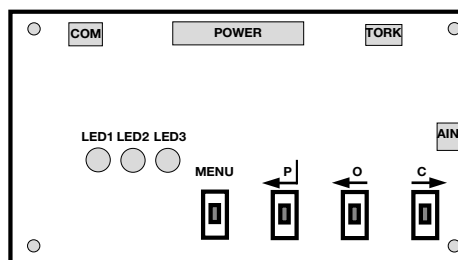

### Colours of diodes:

LED1 – yellow (menu number)  
 LED2 – red (parameter value)  
 LED3 – green

**Push-buttons and signal lamps LED on control unit DMS2.ED.S and DMS2.ED.S90**

Yellow	Red	Green	State
-	-	-	System without feeding
-	-	lit on	Everything OK – working regime (remote, local or switched off control)
-	blinking	lit on	Error or warning – working regime (remote, local or switched off control)
lit on	-	lit on	Enter or exit of Setting of parameters by means of push-buttons or Setting of parameters by means of PC
blinking	-	lit on	Setting of parameters by means of push-buttons
blinking	blinking	lit on	
blinking	blinking	lit on	

In adjustment, follow the paragraphs "VERIFICATION of APPARATUS FUNCTION And its LOCATION", "fitting on VALVE" and "ADJUSTMENT of ACTUATOR with VALVE" of these instructions.

For safety reasons, the system is delivered in the state of induced error of Calibration when the functions are limited in order to reduce the risk of damage to the actuator by wrong wiring.

## Record of position CLOSED, OPEN and AUTOCALIBRATION

- The actuator must be adjusted in such a way that the recorded position would switch off the actuator before it is switched off by torque. For tight closure, the torque relay for torque Closed is only connected into the control circuit. The actuator can be shifted either manually or electrically. The actuator in version CONTROL can be started from menu MOTOR in program DMS2. In this case, the actuator does not react to the set position and can only be stopped by the torque relay. In controlling from menu MOTOR, no torque may be induced. The torque must be left manually.
- If, during adjustment, the torque is reached in the end-limit position, the torque must be left by means of a hand wheel.
- The actuator is set to position Closed and position Closed is stored by long pressing of push-button C (without entering the Menu).
- The actuator is set to position Open and position Open is stored by long pressing of push-button O.
- The calibration routine is started by means of push-button P (in remote control) that, in the three-position regulation, will measure actual inertial masses of the system and store them into the memory of the control unit. In the two-position regulation, pressing of push-button P only cancels the error of Calibration.
- In recording the end-limit positions, signalling relays and the position transducer are also set.
- In case the actuator stroke is to be increased and the switching off is set to "from position", the actuator will switch off during shifting in position O or 100 %. To further change the position, press C or O, and, while

keeping it depressed, the actuator can be further shifted. After required position is reached, it is stored to memory by pressing push-button C or O.

**Parameters that can be changed by user are set by manufacturer as follows:**

- |  |  |
|--|--|
| 1. Tripping torques:                       | 100% or required value <i>(it is not recommended to change the value without consulting the supplier of the valve, etc.)</i> . |
| 2. Relay 3 and relay 4:                    | signalization SZ 1 % and SO 99 % of stroke   |
| 3. Time of blocking:                       | 0 s  |
| 4. Position of blocking:                   | 5 % of stroke from end-limit positions <i>(it is not recommend to change the value by more than 10 %)</i>                      |
| 5. Characteristics of position transducer: | closed 4 mA, open 20 mA  |
| 6. Relay READY:                            | errors + warning + not remote  |

In version CONTROL:

- |  |   |
|--|---|
| 1. Setting of control signal:                  | closed 4 mA, open 20 mA   |
| 2. Insensitivity of actuator in regulation:    | 1 % <i>(it is not recommended to set insensitivity higher than 3 %)</i> |
| 3. Response in case of loss of control signal: | stop  |
| 4. Way of switch off in end-limit positions:   | torque + PO + PZ  |

**Overview of MENU**

**BROWSING THROUGH MENU**

- The setting regime is entered by pressing and keeping depressed push-button **MENU** for at least 2 s; LED1 is then lit on.
- Shortly press **MENU** to select the basic MENU – menu M1 to M8 (*LED1 signalizes the menu number*); by short pressing of P, O, C they are entered (*LED2 signalizes particular parameter*).
- Shortly press P to select required value of the parameter. In case the parameter can be set to several values, they are changed by short pressing of P (*number of blinking of LED2 indicates its value*). Keep pressing of P to record the chosen parameter; the record is confirmed by lighting on of LED2.
- Shortly press **MENU** to gradually set the required menu and parameters.
- After setting all required parameters, exit the setting menu by pressing and keeping depressed push-button **MENU** for at least 2 s. The setting menu will also be left in case that no push-button is pressed within 1 minute.

**MENU 1 – Setting of tripping torques**

- After entering the menu by means of push-button C or O, select required torque.
- Shortly press P to select the set value of the parameter 50 – 100 % (*5 – 10 blinking of LED2*) and keep pressing push-button P to store the parameter to memory.

**MENU 2 – Setting function of signalling relays**

- Basic setting of the signalling relays is SZ 1 % and SO 99 % of stroke.
- In case different setting is required, it can be changed after shifting the actuator to required position by means of push-button C or O.
- Using push-button P, perform basic setting SZ 1 % and SO 99 % of stroke.

**MENU 3 – Setting of blocking of torque in end-limit positions**

- Shortly press P to select the set value of blocking time 0 – 20 s (*0 – 20 blinking of LED2*) and keep pressing push-button P to store the parameter to memory.
- Keep pressing push-button C to store actual position for blocking torque on the side Closed to memory.
- Keep pressing push-button O to store actual position for blocking torque on the side Open to memory.

**MENU 4 – Setting transducer characteristics**

- Shortly press P to select the value 4 – 20 mA – 1x blinking of LED2 or 20 – 4 mA – 2x blinking of LED2, and keep pressing push-button P to store the parameter to memory.

**Other menus only serve for board setting in version Control**

**MENU 5 – Setting control signal in 3P regulation**

- Shortly press P to select value
 

4 – 20 mA	- 1x blinking of LED2,
or 20 – 4 mA	- 2x blinking of LED2,
or 0 – 20 mA	- 3x blinking of LED2,
or 20 – 0 mA	- 4x blinking of LED2
- and keep pressing push-button P to store the parameter to memory.

### MENU 6 – Setting insensitivity in three-position regulation

- Shortly press P to select value 1 – 10 % (1 – 10x blinking of LED2) and keep pressing push-button P to store the parameter to memory.

### MENU 7 – Response in case of losing control signal in three-position regulation

- Shortly press P to select value OPEN - 1x blinking of LED2,  
or CLOSE - 2x blinking of LED2,  
or STOP - 3x blinking of LED2,  
and keep pressing push-button P to store the parameter to memory.

### MENU 8 – Way of switching off in end-limit positions in 3P regulation

- Shortly press P to select value TORQUE - 1x blinking of LED2,  
or TORQUE + PO - 2x blinking of LED2,  
or TORQUE + PZ - 3x blinking of LED2,  
TORQUE + PO + PZ - 4x blinking of LED2,

And keep pressing push-button P to store the parameter to memory.

## 7.3 PROCEDURE OF SETTING PARAMETERS BY PROGRAM DMS2

- Before starting the actuator, it is necessary to set some parameters of the system by means of program DMS2 on PC.
- For safety reasons, the system is delivered in the state of induced error of Calibration when the functions are limited in order to reduce the risk of damaging the actuator by wrong wiring. In controlling the actuator from program DMS2, its run is stopped when any torque is induced.

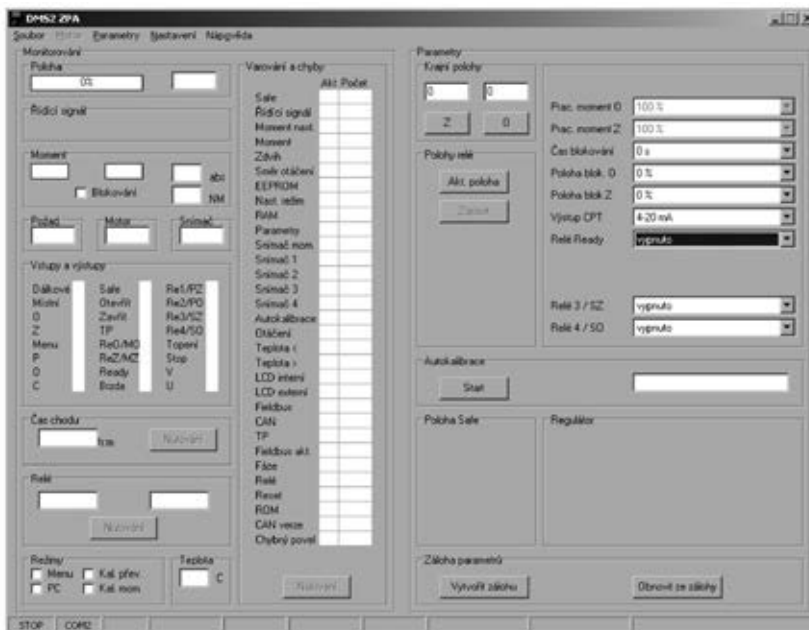

Main window of setting program



Selection of electronics

### Working torque

- Check and, if necessary, set the value of working torque 50 – 100 % in program DMS2.

### Record of positions OPEN, CLOSED and AUTOCALIBRATION

The actuator should be adjusted so that the recorded position would stop the actuator before it is switched off by torque. The actuator is shifted manually or electrically. The actuator in version CONTROL can be started from menu MOTOR in program DMS2. In this case, the actuator does not respond to the set position and is switched off by torque. In controlling from menu MOTOR, no torque may be induced. The torque should be left manually.

Record of position CLOSED:

- In the required position, press push-button Z in the program and confirm the approved record.

Record of position OPEN:

- In the required position, press push-button O in the program and confirm the approved record.

The recorded values are confirmed by pressing push-button START in program DMS2. For the actuator in version CONTROL, change over the actuator to remote control and, by pressing push-button START, start the autocalibration. By short starting of the motor in both directions, the actuator measures inertia and changes over to the regulating regime. Information on the course of autocalibration is signalized next to push-button START. The autocalibration cannot be started in case the torque relay is switched off. The torque should be left manually.

## Other parameters

Check and, if necessary, change other parameters:

Control signal	4 – 20 mA, 20 – 4 mA, 0 – 20 mA, 20 – 0 mA
Insensitivity	1 – 10 %
Function in case of error	open, close, stop, to position
Time of torque blocking in end-limit positions	0 – 20 s
Position of torque blocking in end-limit positions	1 – 10 %
Output of position signal	4 – 20 mA, 20 – 4 mA
Function READY	combined error

**Note:** Signal READY is brought out as contact of the relay on the terminal board. If the state ERROR or WARNING is not detected (setting can be made of what is to be evaluated as error or warning), the contact is closed; in case of error, warning, or if feeding of electronics is interrupted, the contact is opened. The state of the relay READY is indicated by the LED diode on the source board.

## 7.4 AUTODIAGNOSTICS

DMS2 ED performs continuously its diagnostics and, if a problem is detected, it reports warning or error. The warning or error is signalized by LED of the display and, possibly, by relay Ready. The warning has no effect on operation of the system, the error stops the actuator.

Assigning or switching off of warnings and errors is set in window “Warning and error” of the setting program (*it is opened by clicking one of parameters Warning 1 – 4 or Error 1 – 4 in window “Parameters”*).

The error or warning are reported by opening the relay READY and by blinking of the red LED diode on the control unit. Particular error is specified by program DMS2 or on the display.

## 7.5 RESTORING PARAMETERS FROM BACKUP

With the feeding switched off, press push-buttons O and C at the same time. Then, switch on feeding and wait until red and yellow LED diodes light on. The backup parameters are read.

## List of warnings and errors

No.	Name	Warning <sup>1</sup>	Error <sup>1</sup>	Description
1	Safe *	X		Input Safe activated
2	Control signal	X		Value of control signal $\leq 3$ mA ( <i>it applies to ranges 4 – 20/20 – 4 mA</i> )
4	Torque	X		Induced torque beyond end-limit positions or disconnected torque sensor
6	Thermal protection		X	Thermal protection input activated
7	Sense of rotation		X	Reverse sense of rotation ( <i>for CONTROL only</i> )
8	EEPROM	X		Wrong control sum of parameters in EEPROM
9	RAM		X	Wrong control sum of parameters in RAM
10	Parameters		X	Wrong parameters in EEPROM
11	Setting regimes	X		Setting regime from push-buttons or PC
12	Torque sensor		X	Disconnected or defective torque sensor
13	Sensor 1		X	Error of sensor of position 1 ( <i>lowest stage</i> )
14	Sensor 2		X	Error of sensor of position 2
15	Sensor 3		X	Error of sensor of position 3
16	Sensor 4		X	Error of sensor of position 4 ( <i>highest stage</i> )
17	Calibration	X		Autocalibration not carried out
18	Torque setting		X	Wrong setting of torques ( <i>parameters Torque O/Z 50/100 %</i> )
19	Stroke		X	Wrong setting of stroke ( <i>parameters Position O/Z</i> )
20	Rotation error		X	The actuator does not rotate
21	High temperature	X		Permitted max. temperature exceeded ( <i>parameter Temperature max.</i> )
22	Low temperature	X		Permitted min. temperature exceeded ( <i>parameter Temperature min.</i> )
23	LCD internal *	X		Display of LCD internal does not communicate or not added in parameter CAN of configuration
24	LCD external *	X		Display of LCD external does not communicate or not added in parameter CAN of configuration
25	Fieldbus *	X		Module of industrial bus does not communicate or not added in parameter CAN of configuration
26	CAN *	X		Error of bus CAN ( <i>short circuit, interruption, only sensor communicates</i> )
27	Fieldbus activity*	X		Connection to industrial bus not active
28	Phase *		X	Inverse order of phases or some phase missing
29	Relay of service life	X		Service life of relay MO/MZ at CONTROL exceeded ( <i>parameter Relay of service life</i> )
30	Reset	X		Non-standard Reset of unit induced ( <i>watchdog etc.</i> )
31	ROM		X	Wrong control sum of program in ROM
32	CAN version *	X		Sensor, LCD display or module Fieldbus have incompatible versions of firmware
33	Wrong command *		X	Commands Open and Close entered at the same time
34	Wrong inertia	-	-	Wrong inertia measured by autocalibration ( <i>for autocalibration only</i> )
35	Wrong run-down	-	-	Wrong run-down measured by autocalibration ( <i>for autocalibration only</i> )
41	Wrong position		X	Servo-drive is in position 25% behind working stroke

<sup>1</sup>) Assignment can vary depending on the version of firmware of the sensor control unit.

\* Applies to DMS2 only.

### Memory of number of induced warnings and errors

- For all ascertained warnings and errors, DMS2.ED uses counters of occurrence of these warnings and errors during operation of the system.
- Values of the counters are stored to the EEPROM memory and are preserved even in case of the power supply fall-out.
- Reading of the counters is possible by means of the program for PC
- Clearing of the counters is possible by means of the program for PC with the level of authorization “SERVICE”.

### Memory of recently induced warnings and errors

- DMS2.ED stores three recently induced warnings and errors to the EEPROM memory.
- Recent warnings and errors can be displayed and erased by means of the program for PC.

Example of wiring diagram of electronics **DMS2 ED** in version **Substitution of electro-mechanical board**  
with single-phase electric motor

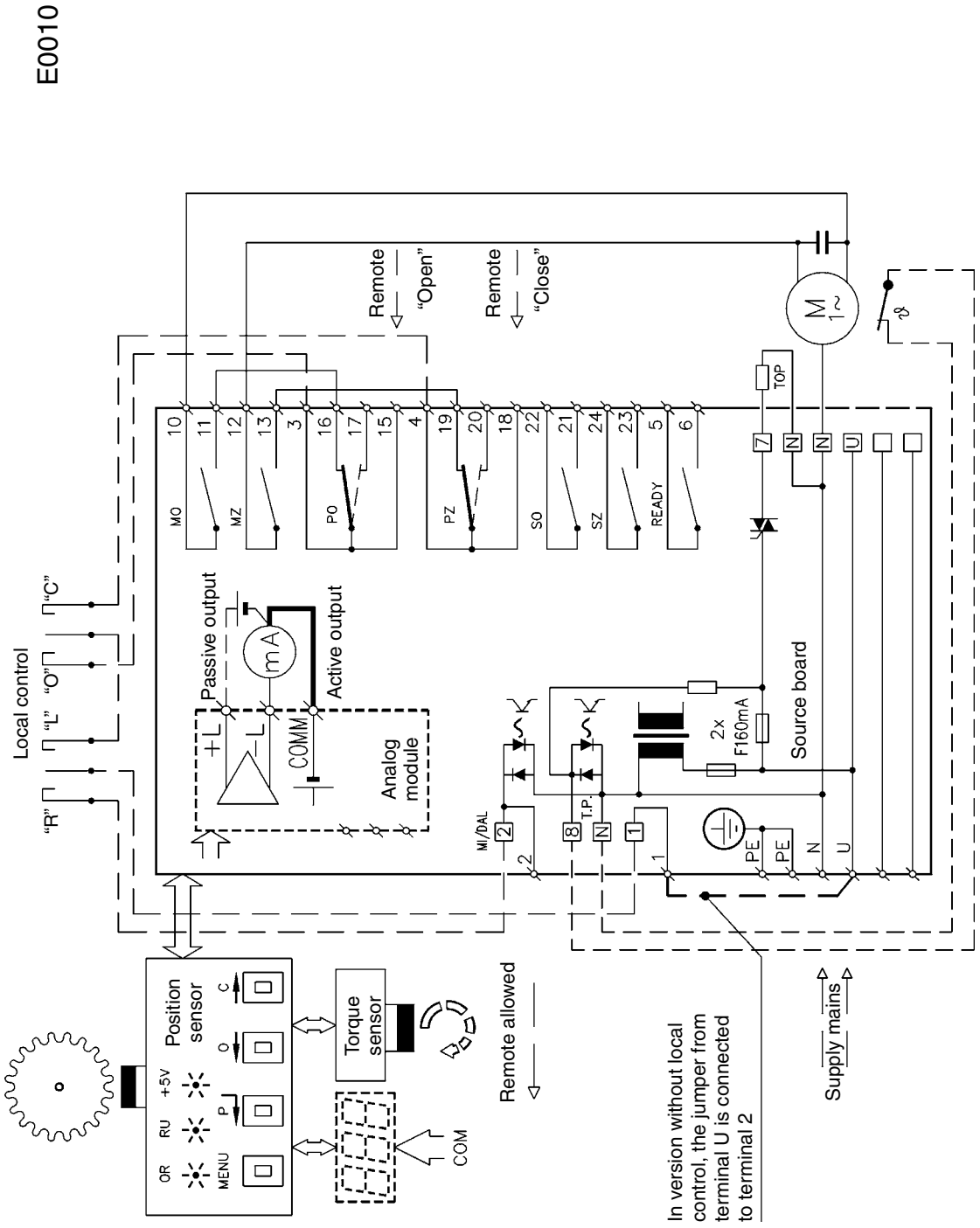

E0010

**Note:** Here, contacts of relay MO, MZ, SO, SZ are shown with power supply switched off; with power supply switched off contacts PO, PZ are shifted to the position drawn in dashed line.

Example of wiring diagram of electronics **DMS2 ED** in version **Substitution of electro-mechanical board** with three-phase electric motor

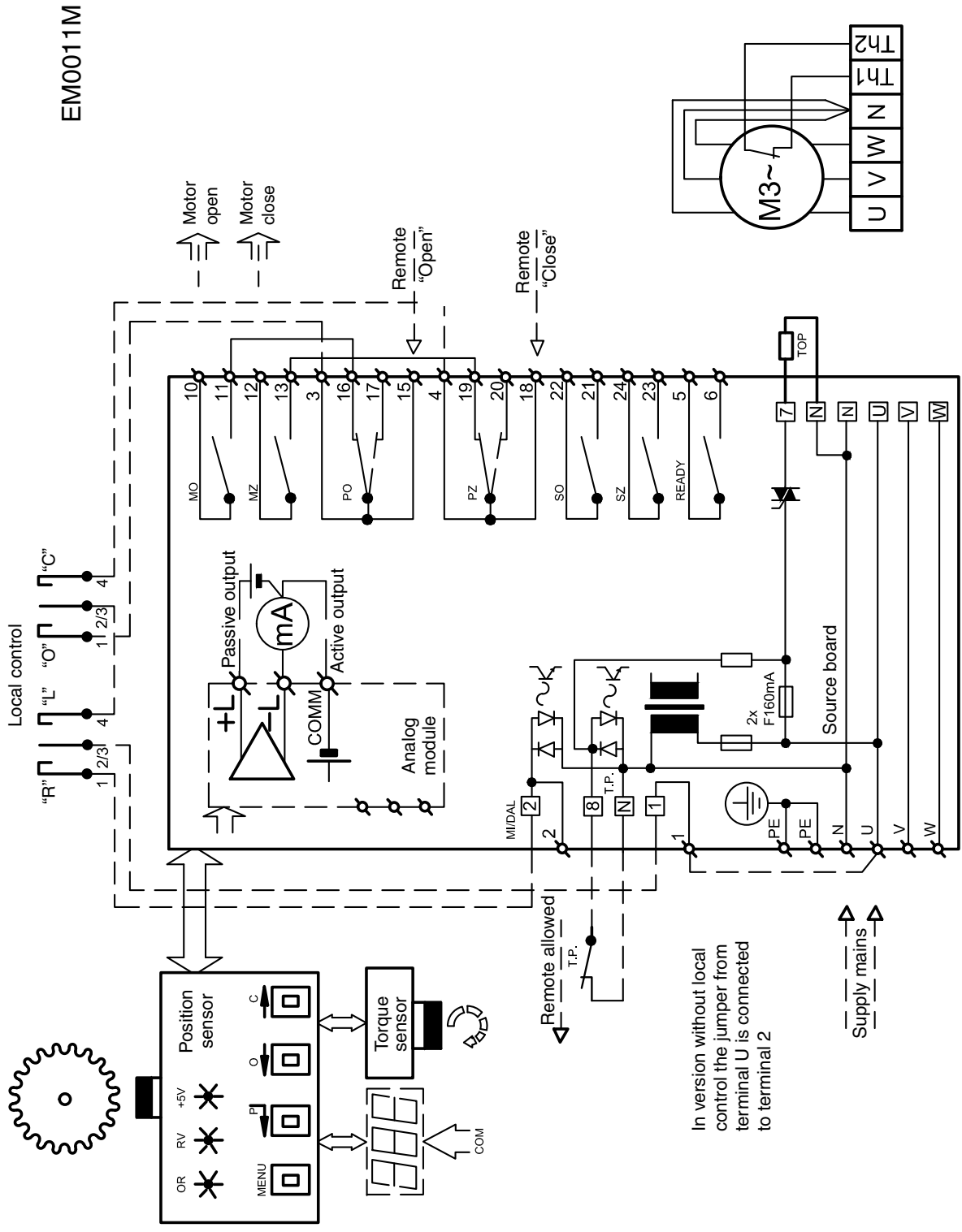

**Note:** Here, contacts of relay MO, MZ, SO, SZ are shown with power supply switched off; with power supply switched on, PO, PZ are shifted to the position drawn in dashed line.



# Example of DMS2ED electronics connection with phase failure monitoring module and dual local control switch

E0102

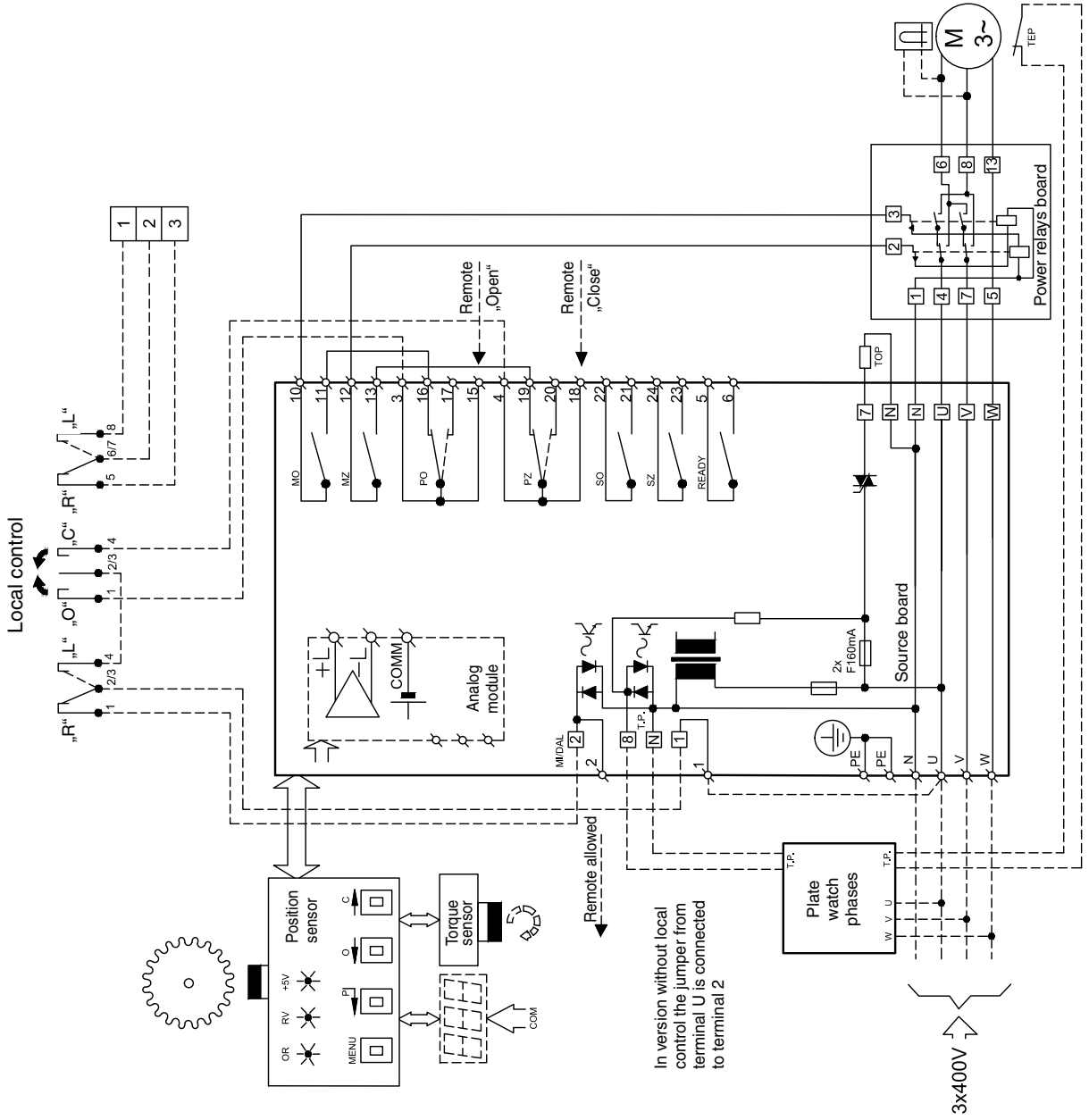

Example of wiring diagram of electronics **DMS2 ED** in version **Control** with single-phase electric motor

E0012

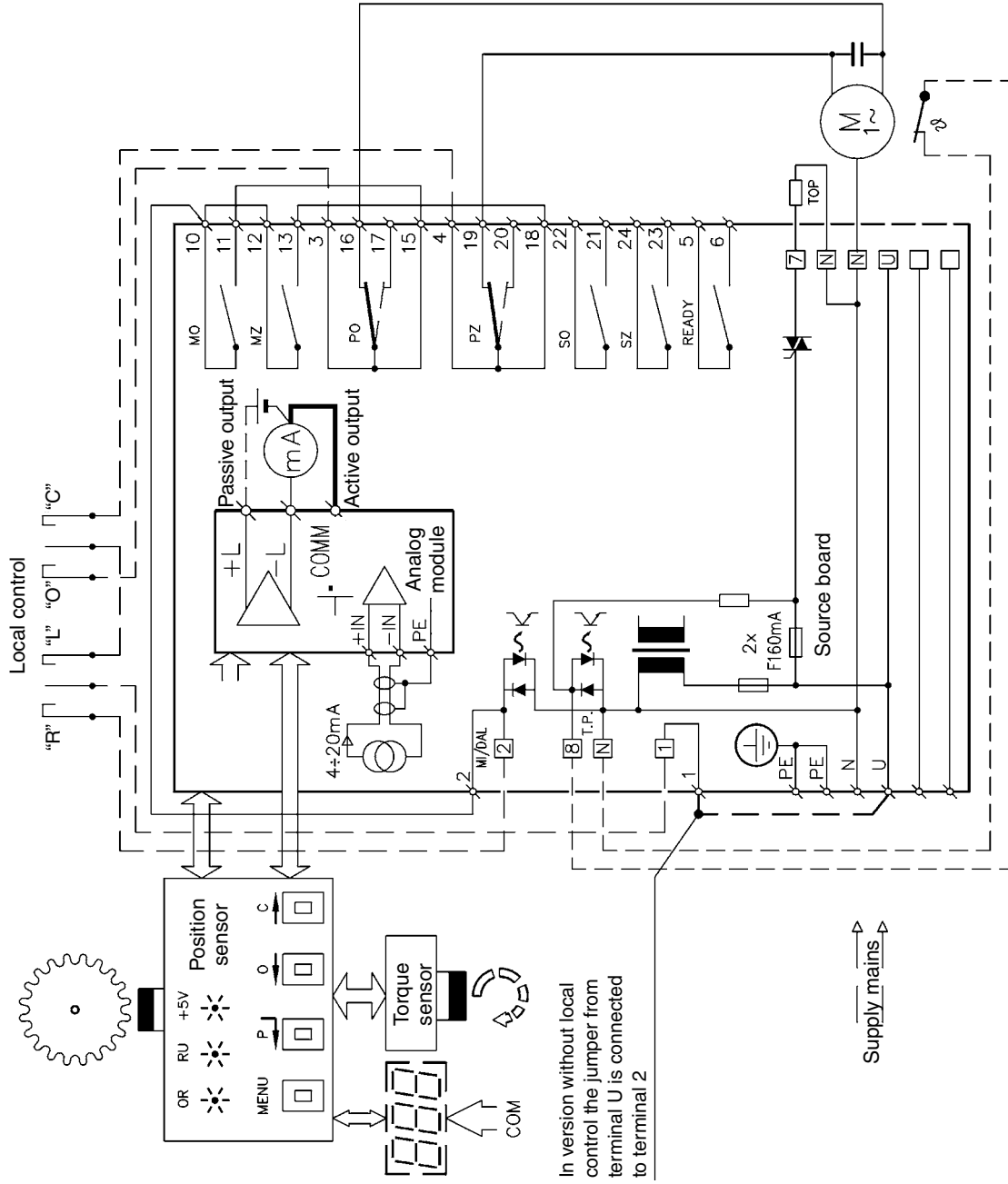

Example of wiring diagram of electronics **DMS2 ED** in version **Control** with three-phase electric motor

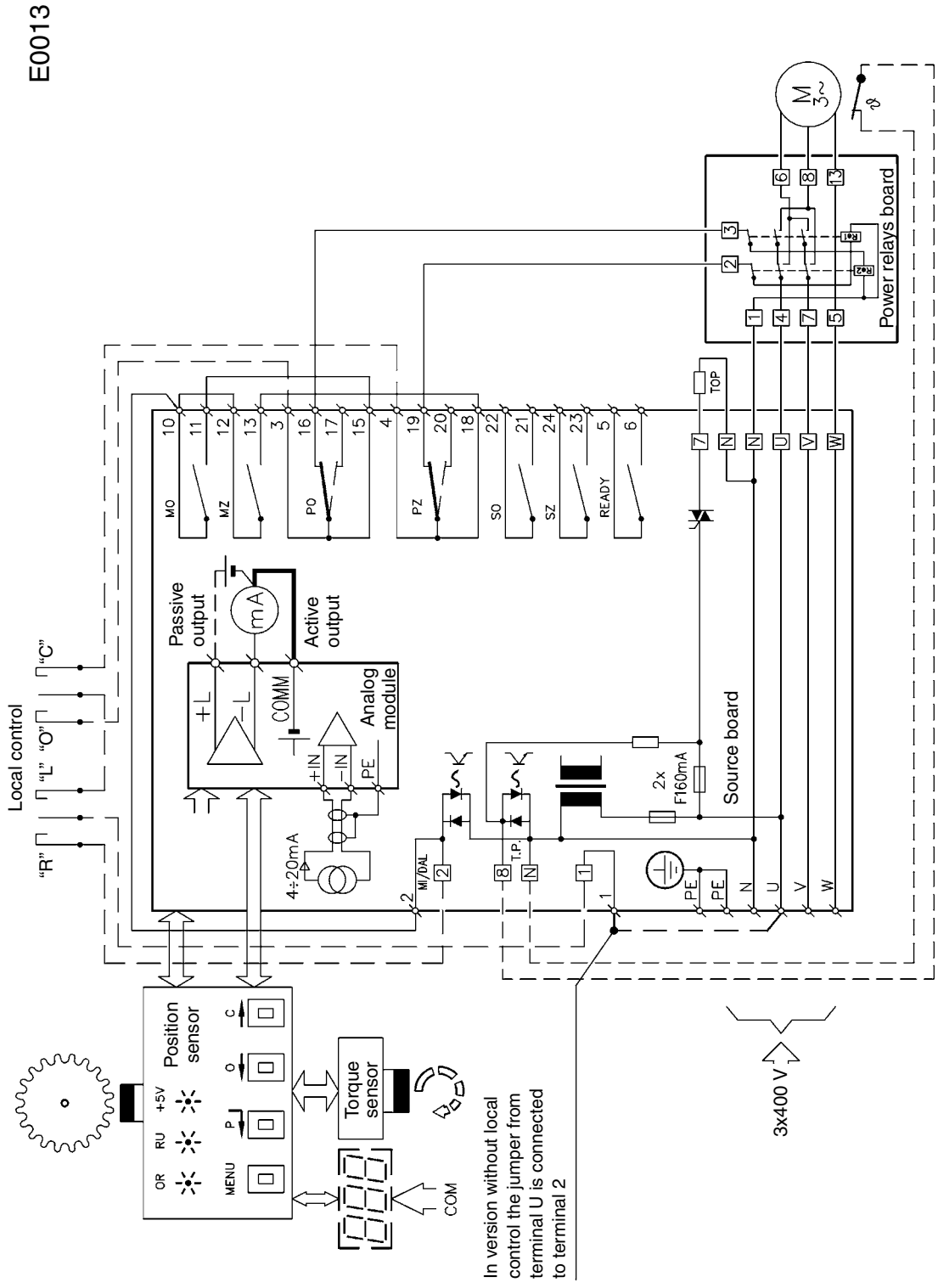

## 7.6 DMS2

### Main properties of DMS2:

- Complete control of the actuator run of the two- and three-position regulation or connection to the industrial bus Profibus.
- Synoptic signalization of operation and service data on the character LCD display 2 x 12.
- Autodiagnosics of error reports on the LCD display, memory of recent failures and number of occurrences of respective failures.
- Setting of parameters by the PC program and by local control provided that the actuator is fitted with local control.

### Basic outfit:

The control unit is the main part of the system DMS2; it comprises:

- Microcomputer and memory of parameters
- Position sensors
- 2 signalling LED
- Connectors for connecting the torque sensor, relay board, and two-position inputs, source board, communication adapter, LCD display, and local control

**Torque unit** provides for scanning torque by the contactless sensor

**Source unit** – two types exist:

DMS2.ZAN for the two-position or three-position control of the actuator by binary signals “Open” and “Close” or by analog signal 0(4) – 20 mA.

DMS2.ZPR for controlling the actuator by the industrial bus Profibus.

Both units include the feeding source for electronics, two relays for controlling the power switches (*contactors or contactless switches*) of the electric motor, guarding of sequence of phases (*in case the actuator is fed by three-phase voltage*), circuits for connecting the anticondensation heater, and input terminals for connecting the thermo-contact from the electric motor. The units are fitted with the power terminal board for connecting the power supply. The units are fitted with a connector for the display and local control.

### Unit DMS2ZAN also contains:

- input circuits for the two-position and three-position control of the actuator and terminals for connecting external control signals
- input of signal SAFE – information on external failure
- relay – total of five; four (*signalling*) can be set for reporting of position, torque, or other operation states of the actuator; the fifth (*Ready*) is used for reporting of errors, warnings, and other states when the actuator cannot faultlessly perform its function, and the terminals to which contacts of the relay are connected
- circuits of the feedback current signal – information on position of the actuator output shaft

### Unit DMS2.ZPR also contains:

- circuits for communication with the superior control system through the industrial bus Profibus DP, input and output terminals for connecting the bus, and termination resistors with a switch.

**Display unit** – two-row display, 2 x 12 alpha-numeric characters

**Unit of push-buttons** – sensors of push-buttons “*open*”, “*close*”, “*stop*” and the rotary switch “*local, remote, stop*”.

*The actuator can be fitted with contactors.*

## 7.7 PROCEDURE OF SETTING PARAMETERS BY PROGRAM DMS2

Before putting the actuator into operation, it is necessary to set some parameters of the system by means of program DMS2 on PC.

Before adjustment, check the actuator according to the paragraph ASSEMBLING AND PUTTING THE ACTUATOR INTO OPERATION.

### Warning:

*For safety reasons (reduced risk of damage to the actuator by wrong wiring), the system is delivered in the state of the induced error of CALIBRATION when the functions are limited and, during controlling the actuator from program DMS2, its run is stopped if any torque is induced.*

### Note:

*The setting program is the same for electronics DMS2 ED. See the figure on page 11 for the main window and the window of Selection of electronics.*

## Working torque

- Check and, if necessary, set the value of the working torque 50 – 100 % in program DMS2.

## Tripping in end-limit positions

- Check and, if necessary, set the way of tripping in the end-limit positions::
- Torque
- Torque + position O
- Torque + position Z
- Torque + position O + Z

## End-limit positions - working stroke

- Position Z
  - Shift to position Closed either manually or by means of menu Motor in program DMS2.
  - The actuator can only be controlled by means of the program if no torque is induced. The torque should be left manually.
  - Press push-button Z to confirm consent with the record.
- Position O
  - Shift to position Open either manually or by means of menu Motor in program DMS2.
  - The actuator can only be controlled by means of the program if no torque is induced. The torque should be left manually.
  - Press push-button O to confirm consent with the record.

## Autocalibration

- The autocalibration can only be started by means of the program if no torque is induced. The torque should be left manually.
- The autocalibration is started by push-button Start in program DMS2.
- Wait until the autocalibration is completed; information on its course is signaled next to push-button Start.

## Other parameters

Check and, if necessary, change other parameters:

Control signal	4 – 20 mA	20 – 4mA	0 – 20 mA	20 – 0 mA
	2 position	Bus		
Insensitivity	1 – 10 %			
Function SAFE	Open	Close	Stop	To position
Active SAFE	0 V	230 V		
Time of blocking torque in end-limit positions	0 – 20 s			
Position of blocking torque in end-limit positions	1 – 10 %			
Output of position signal	4 – 20 mA	20 – 4 mA		
Function READY - Combined error	Switched off	Warning	Errors	Warning or error
	Errors or not remote	Errors or warning or not remote	Torque “O” or “Z”	
Relay 1 – 4	Switched off	Position O	Position Z	
	Torque O	Torque Z	Torque and position O	Torque and position Z
	Opening	Closing	Motion	Position
	position N	Local control	Emote control	Control switched off
	Torque O/Z	Motion - blinker		
Position Relay 1 – 4	0 – 100 %			

**Note:** SAFE - input information on the error of an external device can be set so that the actuator would respond as to its own error.

## Autodiagnostics

The table List of errors – same as for electronics DMS2 ED (page 13)

### Memory of number of induced errors

- For all detected errors, DMS2 uses the counter of occurrence of these errors during operation of the system.
- Values of the counters are stored to the EEPROM memory and are preserved even in case of the power supply fall-out.
- Reading and clearing of the counters is possible by means of the program for PC.

### Memory of recently induced errors

- DMS2 stores 3 recently induced errors to the memory EEPROM.
- DMS2 provides for displaying the errors by means of the PC program or the switches of the local/ remote control.
- The display in MENU 22 INFORMATION shows ERROR 1, ERROR 2, ERROR 3. ERROR 1 is the latest error.

### Setting parameters by means of push-buttons of local control

Signalization of operation regimes by means of diodes LED on the position sensor board:

Red	Green	State
-	-	System without feeding
-	lit on	Everything OK – working regime ( <i>remote, local, or switched off control</i> )
blinking	lit on	Error or warning – working regime ( <i>remote, local, or switched off control</i> )
lit on	lit on	Setting parameters by means of push-buttons or PC

Signalization of operation regimes by means of the display:

*The display shows the actuator position in %, the state of local control and/or reaching of torque. In case of an error, blinking of this state alternates with number of actual error. In case of more errors, these errors repeat cyclically.*

### Overview of MENU

	Name	Parameter value	Meaning
1	JAZ/LANGUAGE	CESKY	Menu LANGUAGE
		ENGLISH	
2	POLOHA O, Z	POL.OTEVR.	End-limit position Open or Closed
		POL.ZAVRENO	
3	KALIBRACE	SPUSTIT	Starting of autocalibration
4	KONCOVA POL.	MOMENT	Tripping in end-limit positions
		MOMENT+POL.O	
		MOMENT+POL.Z	
		MOMENT+P.O+Z	
5	MOMENT PR. O	50 – 100 %	Working torque Open ( <i>selection 50 – 69 % depends on parameter Torque min.</i> )
6	MOMENT PR. Z	50 – 100 %	Working torque Closed ( <i>selection 50 – 69 % depends on parameter Torque min.</i> )
7	CAS BLOK.MOM	0 – 20 s	Time of torque blocking
8	POLOHA BL. O	0 – 50 %	Position of torque blocking Open
9	POLOHA BL. Z	0 – 50 %	Position of torque blocking Closed
10	CPT	4 – 20 mA	Characteristics of current transducer
		20 – 4 mA	
11	RIDICI SIGN.	4 – 20 mA	Analog control signal
		20 – 4 mA	
		0 – 20 mA	
		20 – 0 mA	
12	NECITLIVOST	1 – 10 %	Range of insensitivity
13	SAFE	OTEVIRAT	Response to signal Safe and loss of control signal
		ZAVIRAT	
		ZASTAVIT	
		POLOHA	

	Name	Parameter value	Meaning
14	SAFE AKTIV.	0 V	Active signal Safe
		230 V	
15	TP SAFE	blokuje SAFE	Response with thermal protection activated
		SAFE aktivni	
16	TP NULOVANI	AUTOMATICKY	Zeroing of thermal protection
		MISTNIM OVL.	
17	RELE READY	VYPNUTO	Function of Relay Ready
		VAROVANI	
		CHYBY	
		VAR.+CHYBY	
		CHYBY+NENÍ D	
		VAR+CHYBY+ND	
		MOMENT O/Z	
18	RELE 1	VYPNUTO	Function of Relay 1
		POL.OTEVRENO	
		POL. ZAVRENO	
		MOM.OTEVRENO	
		MOM. ZAVRENO	
		POL.O.+MOM.O	
		POL.Z.+MOM.Z	
		OTEVIRA	
		ZAVIRA	
		POHYB	
		POLOHA	
		POL. N.	
		OVL. MISTNI	
		OVL. DALKOVE	
		OVL. VYPNUTO	
		MOMENT O/Z	
POHYB-BLIKAC			
19	RELE 2	same as RELE 1	Function of Relay 2
20	RELE 3	same as RELE 1	Function of Relay 3
21	RELE 4	same as RELE 1	Function of Relay 4
22	INFORMACE	SNIMAC	Information on the system
		DISP I	
		DISP E	
		DISP ED	
		FLDBUS	
		CHYBA 1	
		CHYBA 2	
		CHYBA 3	
		MOMENT	
		TEPLOTA	
23	ZALOHA PAR	OBNOVIT PAR	Creation of backup parameters, restoring from backup parameters
		VYTVORIT ZAL	
24	ADRESA	1 – 125	Address of actuator on industrial bus
25	TAKT MOD	VYPNUTO	Mode of cycle regime
		SMER O	
		SMER Z	
		SMĚR O+Z	
26	TAKT BEH	1 – 250 s	Time of motor run down in cycle regime
27	TAKT PAUSA	1 – 250 s	Time of motor pause in cycle regime



Setting actuator by means of push-buttons:

- Shift the change-over switch of local control to position OFF
- Keep pressing push-button STOP to enter the MENU. Using push-buttons O or Z, browse through the MENU (*MENU1 – MENU27*). Shortly press push-button STOP in a selected menu to enter this menu and, using push-buttons O or Z, select the parameter. Keep pressing push-button STOP to store the parameter to memory. Shortly press push-button STOP to exit the setting of parameters and proceed with browsing through another menu.

Keep pressing push-button STOP to exit the set menu; or keep pressing push-button STOP in the item END after the last MENU 27 to terminate the setting regime.

## Setting end-limit positions by means of push-buttons of local control

Shift the change-over switch LOCAL – REMOTE to position OFF. Keep pressing push-button STOP to enter the setting regime. Using push-button “Z”, choose MENU2. Shortly press push-button STOP to select setting of position “O”. Shift the change-over switch to position “LOCAL” and start the actuator. After the required position is reached, shift the switch to position “OFF” and keep pressing of push-button “STOP” to store the position to memory.

Shortly press push-button “Z” to select setting of position “Z”. Shift the change-over switch again to position “LOCAL” and start the actuator in direction “Z”. After the required position is reached, shift the switch to position “OFF” and keep pressing push-button “STOP” to store the position to memory.

Shortly press push-button “STOP” to exit MENU 2. Keep pressing push-button “STOP” to exit the setting regime.

Change over the local control to position OFF, enter the menu (*by long pressing of push-button STOP*), and change over to position “LOCAL”; the actuator can now be shifted by means of push-buttons “O” and “Z” beyond the set end-limit positions. In this case, the actuator will trip after the set tripping torque is reached.

## Autocalibration

In the setting regime choose MENU 3. Shortly press push-button “STOP” to enter MENU 3 and keep pressing push-button “STOP” to start autocalibration. By short starting of the motor in both directions, the actuator will measure inertia. Completion of the autocalibration is announced by the message AUTOCALIBRATION OK.

Shortly press push-button “STOP” to return to MENU 3 and keep pressing of push-button “STOP” to exit the setting regime.

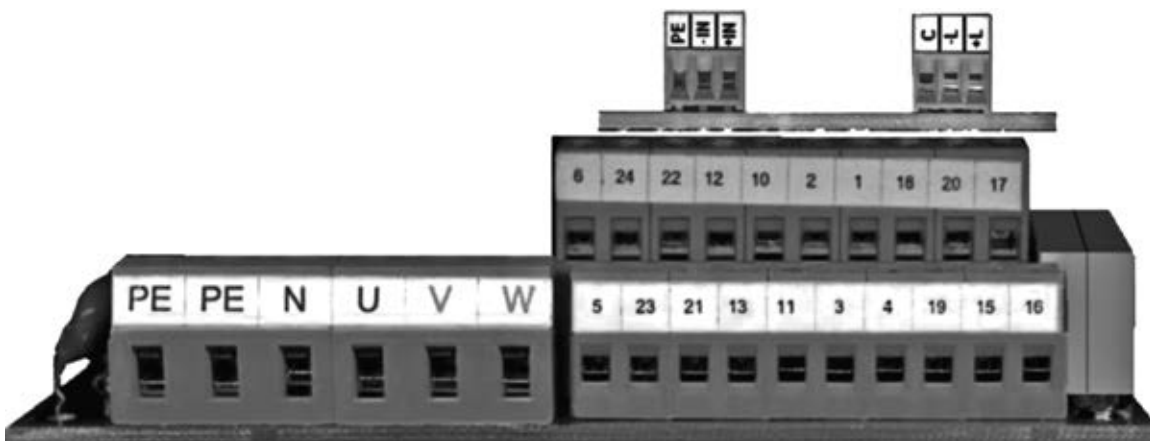

***Terminal board of the actuator with electronics DMS2 ED***

If the actuator is of the single-phase version the power supply is connected only to terminals **PE, N, U**. The terminals **V, W** remain non-connected. If the actuator is of the version “Replacement of electric-mechanical board” with three-phase electric motor without power relays, the electric motor is connected to a separate terminal board (*not shown here*).

## Terminal board of actuator with electronics **DMS2**

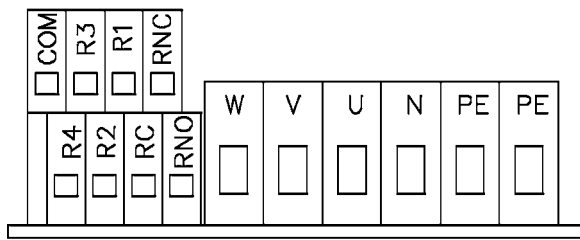

**Terminals on source board**

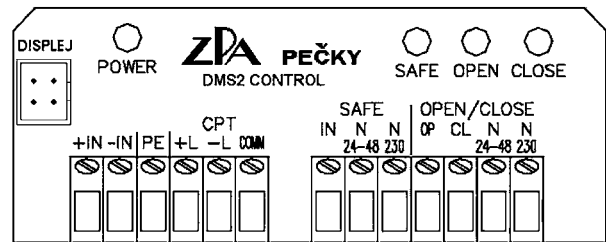

**Terminals in local control box**

If the actuator is of the single-phase version the power supply is connected to terminals **PE, N, U** only. Terminals **V, W** remain unconnected.

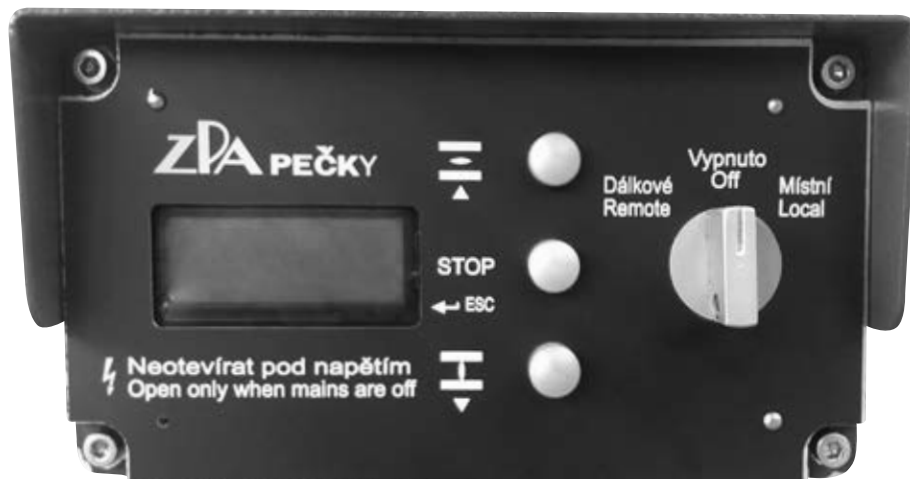

**Local control with two-line display**

**Note:** The setting program enables data to be copied from the memory of parameters of the electronics **DMS2** and **DMS2 ED** into the computer as a file with suffix **“par”** (in the example in the figure the file **52 030.par** is created in the directory **Flash**). The file can serve as a back-up for the case that it will be necessary to replace the position sensor in the given actuator and to set it in the same way as the replaced one; or it can be sent as an enclosure to e-mail to the manufacturing or service firm in solving possible problems..

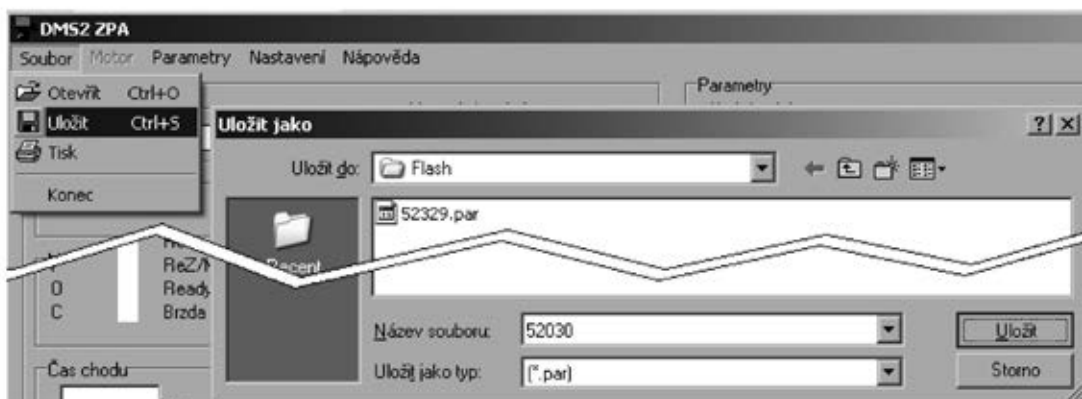

Example of wiring diagram of system **DMS2** in version for control with signals “open” and “close” or in version for control with analog current signal with single-phase electric motor

E0014

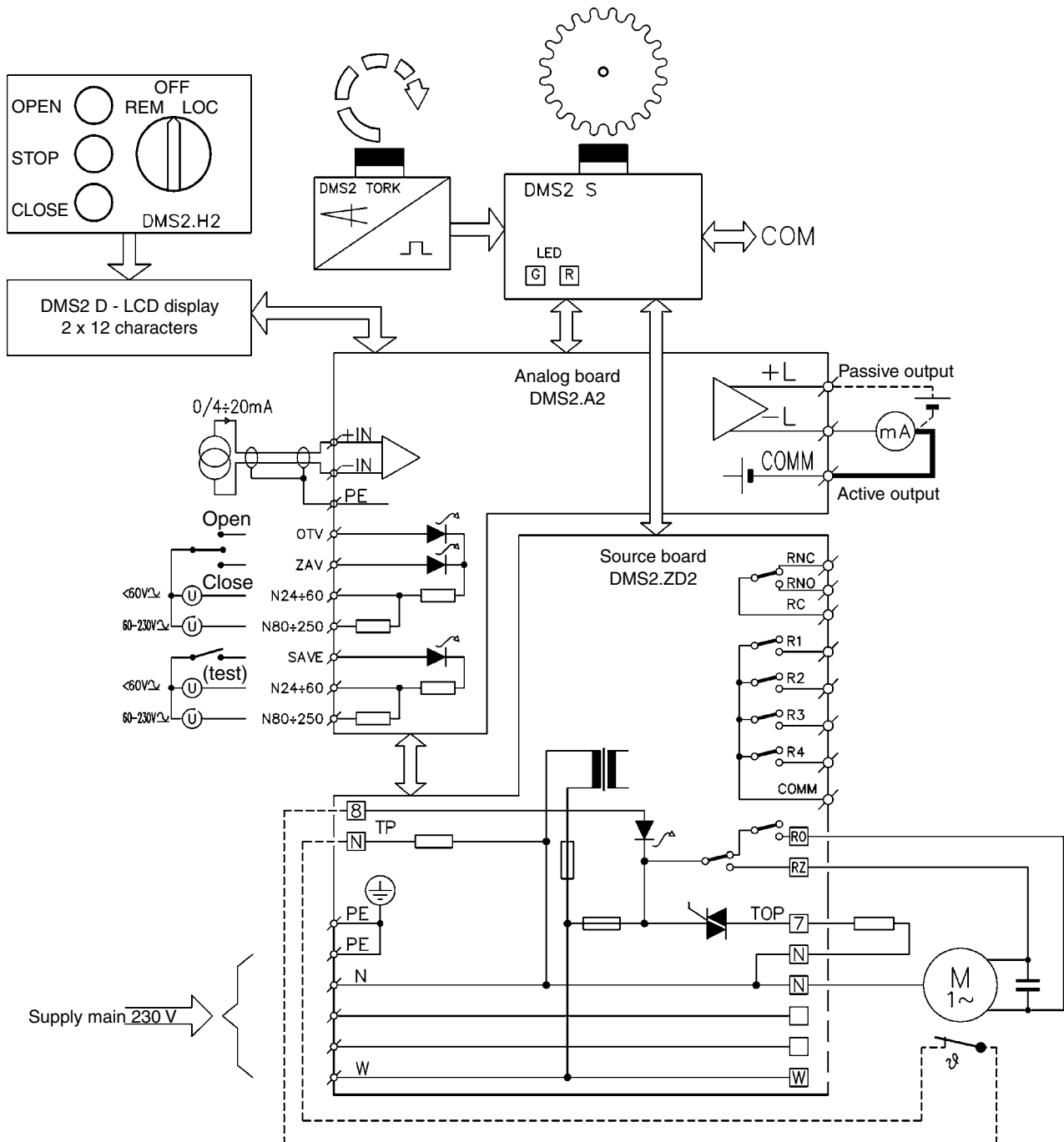

Example of wiring diagram of system **DMS2** in version Profibus with single-phase electric motor

E0015

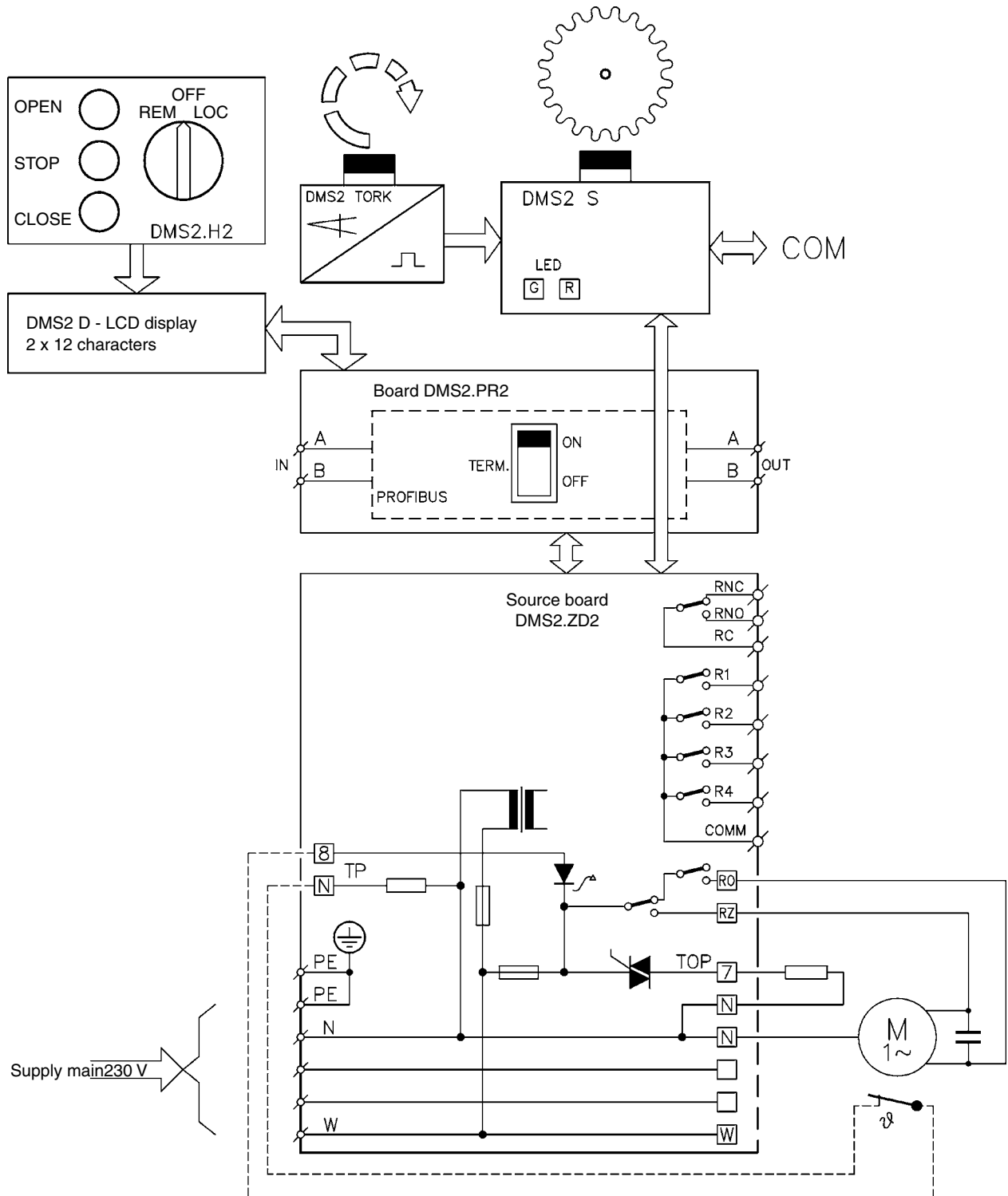

Example of wiring diagram of system **DMS2** in version for control with signals "open" and "close" or in version for control with analog current signal with three-phase electric motor

E0016

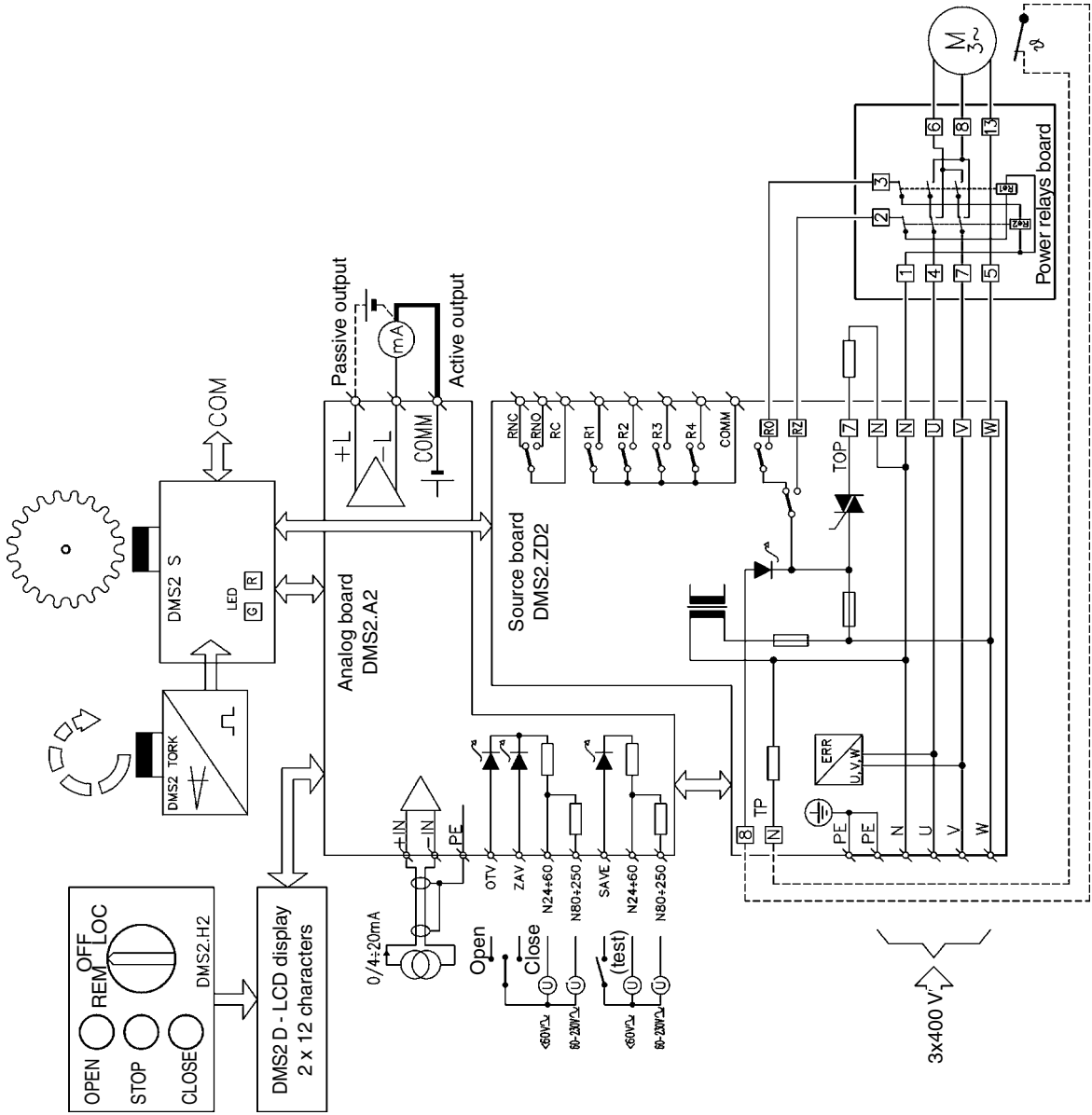

Example of wiring diagram of system **DMS2** in version Profibus  
with tree-phase electric motor

E0017

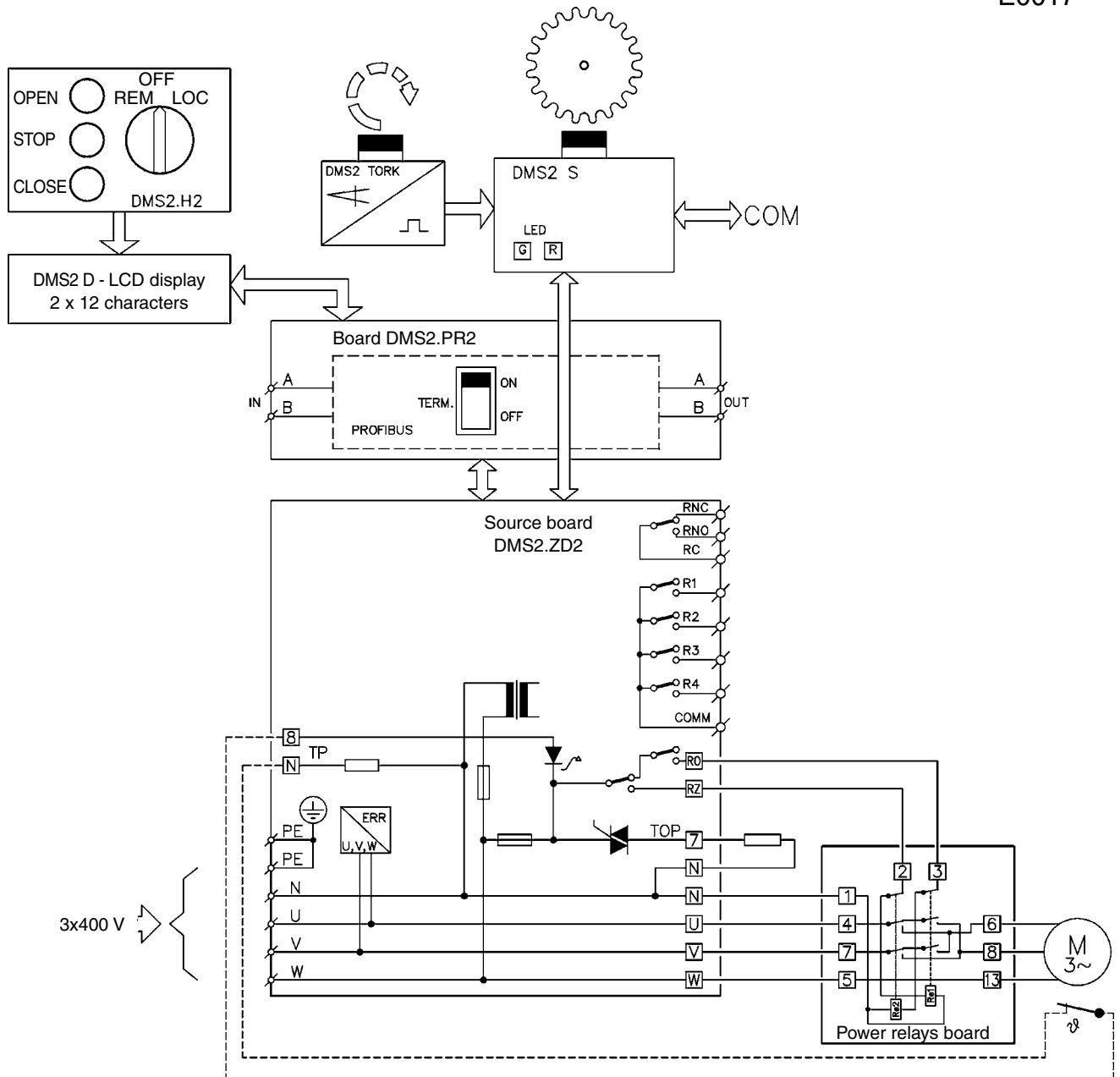

**Table 1 – Electric actuators MODACT MOKED - basic technical parameters**

Type	Type number		Shifting time [s/90°]	Tripping torque [Nm]	Electric motor					Weight [kg]
	basic 1 2 3 4 5	supplem 6 7 8 9 10			Type	Output [W]	Speed [min <sup>-1</sup> ]	Voltage [V]	Current [A]	
MOKED 63	52 325	x x 1 x ED	10	16 – 32	FCJ2B52D	15	2780	1 x 230	0,37	7,4
		x x 2 x ED	20			15	2780	1 x 230	0,37	7,4
		x x 3 x ED	40			15	2780	1 x 230	0,37	7,4
		x x 4 x ED	80	25 – 45	FCT2B54D	4	1270	1 x 230	0,25	7,4
		x x 5 x ED	10		FT2B52D	15	2680	3 x 400	0,10	7,4
		x x 6 x ED	20	15		2680	3 x 400	0,10	7,4	
		x x 7 x ED	40	15		2680	3 x 400	0,10	7,4	
		x x C x ED	40	55 – 110	FCJ2B52D	15	2780	1 x 230	0,37	7,4
MOKED 125	52 326	x x 1 x ED	10	63 – 125	FCJ4C52N	60	2770	1 x 230	0,53	12,7
		x x 2 x ED	20			60	2770	1 x 230	0,53	12,7
		x x A x ED	20			60	2770	1 x 230	0,53	12,7
		x x 3 x ED	40	63 – 125	FCT4C54N	20	1350	1 x 230	0,4	12,3
		x x 4 x ED	80			20	1350	1 x 230	0,4	12,3
		x x 5 x ED	10		FT4C52NA	90	2770	3 x 400	0,34	12,7
		x x 6 x ED	20			90	2770	3 x 400	0,34	12,7
		x x 7 x ED	40			20	1440	3 x 400	0,20	12,7
		x x 8 x ED	80		EAMR56N04A	20	1440	3 x 400	0,20	12,7
						20	1440	3 x 400	0,20	12,7
MOKED 250	52 327	x x 2 x ED	20		125 – 250	FCJ4C52N	60	2770	1 x 230	0,53
		x x 3 x ED	40	60			2770	1 x 230	0,53	21
		x x A x ED	40	60			2770	1 x 230	0,53	21
		x x 4 x ED	80	125 – 250	FCT4C54N	20	1350	1 x 230	0,4	20,5
		x x 5 x ED	160			20	1350	1 x 230	0,4	20,5
		x x 6 x ED	20		FT4C52NA	90	2770	3 x 400	0,34	21
		x x 7 x ED	40			90	2770	3 x 400	0,34	21
		x x 8 x ED	80			20	1440	3 x 400	0,20	21
		x x 9 x ED	160		EAMR56N04A	20	1440	3 x 400	0,20	21
						20	1440	3 x 400	0,20	21
MOKED 500	52 328	x x 2 x ED	20		250 – 500	1 PK 7060-4AB	120	1350	3 x 400	0,42
		x x 3 x ED	40	120			1350	3 x 400	0,42	26
		x x 4 x ED	80	120			1350	3 x 400	0,42	26,3
		x x C x ED	40	EAMRB63L02		90	2780	1 x 230	0,90	27
MOKED 1000	52 329	x x 3 x ED	40	500 – 1000	1 PK 7060-4AB	120	1350	3 x 400	0,42	45
		x x 4 x ED	80			120	1350	3 x 400	0,42	43
		x x 5 x ED	160			120	1350	3 x 400	0,42	43,3
		x x C x ED	80		EAMRB63L02	90	2780	1 x 230	0,90	45



**The type number shall include:**

6th place: letter "U" if the letter C, P, R or S is 7th (the DMS2 electronics are equipped with the actuator) – with the terminal block  
 letter "V" if the letter C, P, R or S is on the 7th position (the actuator is equipped with DMS2) – with the connector  
 letter "T" if the letter C or R is in the 7th position and the actuator will not be equipped with a display and a local control.  
**the character in Table 2**, if the letter E (DMS2 ED electronics) is on the 7th position – with the terminal block  
**K (DMS2 ED electronics)** – with connector

Table 2	0	1	2	3	4	5	6	7	8	9	A	B	C	D	E	F	H	J	K	L	M	N	P	R
Local control		x		x		x		x		x		x		x		x		x		x		x		x
Display			x	x			x	x			x	x			x	x			x	x			x	x
Power relays					x	x	x	x					x	x	x	x					x	x	x	x
Analog module	transmitter								x	x	x	x	x	x	x	x	x	x	x	x	x	x	x	x
	regulator																x	x	x	x	x	x	x	x

7th place: **E** – electric actuator is fitted with electronics DMS2 ED – with terminal board  
**K** – electric actuator is fitted with electronics DMS2 ED – with connector ECTA  
**P** – electric actuator is fitted with electronics DMS2 for connection to Profibus, power relays  
**S** – electric actuator is fitted with electronics DMS2 for connection to Profibus  
**R** – electric actuator is fitted with electronics DMS2 for two- or three-position control \*\*), power relays  
**C** – electric actuator is fitted with electronics DMS2 for two- or three-position control \*\*)

\*\*) Two- or three-position regulation of the actuator is set at the manufacturer. Unless otherwise specified in the order, the actuator will be set for three-position regulation (control by signal 4 – 20 mA).

9th place: the numeral or letter according to Table no. 3 is written.

11th place:

For environment temperature from -25 °C do +70 °C	without marking
For environment temperature from -40 °C do +60 °C	F1

**Table 3 – Connection of electric actuators MODACT MOKED**  
 – designation of the 9th place of the type number

Flange size	Connection	Square sizes [mm]	Square position	Marking of the 9th position in the type number
<b>Type Number 52 325</b>				
F05	keyway	∅ 22		0
F05	square	14	basic	1
F04	keyway	∅ 18		2
F04	square	11	basic	3
F05		14	positioned at a 45°	4
F04		11	positioned at a 45°	5
F04		12	basic	6
F04		12	positioned at a 45°	7
F05		16	basic	8
F05		16	positioned at a 45°	9
<b>Type Number 52 326</b>				
F07	keyway	∅ 28		0
F07	square	17	basic	1
F05	keyway	∅ 22		2
F05	square	14	basic	3
F07		17	positioned at a 45°	4
F05		14	positioned at a 45°	5
F05		16	basic	6
F05		16	positioned at a 45°	7
F07		19	basic	8
F07		19	positioned at a 45°	9
<b>Type Number 52 327</b>				
F10	keyway	∅ 42		0
F10	square	22	basic	1
F07	keyway	∅ 28		2
F07	square	17	basic	3
F10		22	positioned at a 45°	4
F07		17	positioned at a 45°	5
F07		19	basic	6
F07		19	positioned at a 45°	7
F10		24	basic	8
F10		24	positioned at a 45°	9
F10		27	basic	A
F10		27	positioned at a 45°	B
<b>Type Number 52 328</b>				
F12	keyway	∅ 50		0
F12	square	27	basic	1
F10	keyway	∅ 42		2
F10	square	22	basic	3
F12		27	positioned at a 45°	4
F10		22	positioned at a 45°	5
F10		24	basic	6
F10		24	positioned at a 45°	7
F10		27	basic	8
F10		27	positioned at a 45°	9
F12		32	basic	A
F12		32	positioned at a 45°	B
<b>Type Number 52 329</b>				
F12	keyway	∅ 50		0
F12	square	27	basic	1
F12		27	positioned at a 45°	4
F12		32	basic	5
F12		32	positioned at a 45°	6

**Actuator output shaft**

(when viewing towards the local position indicator).

The handwheel tallies with the CLOSED position

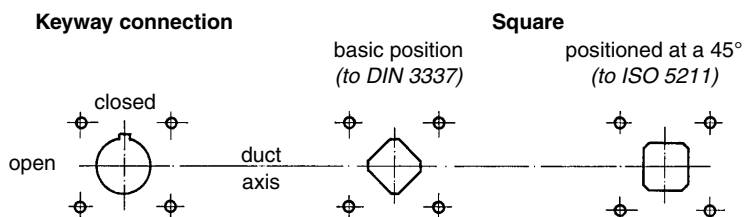

Other connection of the actuator upon special request.

**Addition to table 2 – MODACT MOKED electric actuators with lever adapter**

– mechanical connection (designation of the 9th place of the type number)

Flange size	Connection	Square size s [mm]	Square position	Marking of the 9th position in the type number	Structural design of output
Type number 52 325					
F05	keyway	∅ 22		0	collar
F05	square	14	basic	1	exchangeable inserts
F04	keyway	∅ 18		2	
F04	square	11	basic	3	
F05		14	positioned at a 45°	4	
F04		11	positioned at a 45°	5	
F04		12	basic	6	
F04		12	ppositioned at a 45°	7	
F05		16	basic	8	
F05		16	positioned at a 45°	9	
Actuator with lever adapter				W	
Type number 52 326					
F07	keyway	∅ 28		0	not available
F07	square	17	basic	1	exchangeable inserts
F05	keyway	∅ 22		2	
F05	square	14	basic	3	
F07		17	positioned at a 45°	4	
F05		14	positioned at a 45°	5	
F05		16	basic	6	
F05		16	positioned at a 45°	7	
F07		19	basic	8	
F07		19	positioned at a 45°	9	
Actuator with lever adapter				W	

**Dimensional sketch of MODACT MOKED electric actuator with lever adapter**

Lever

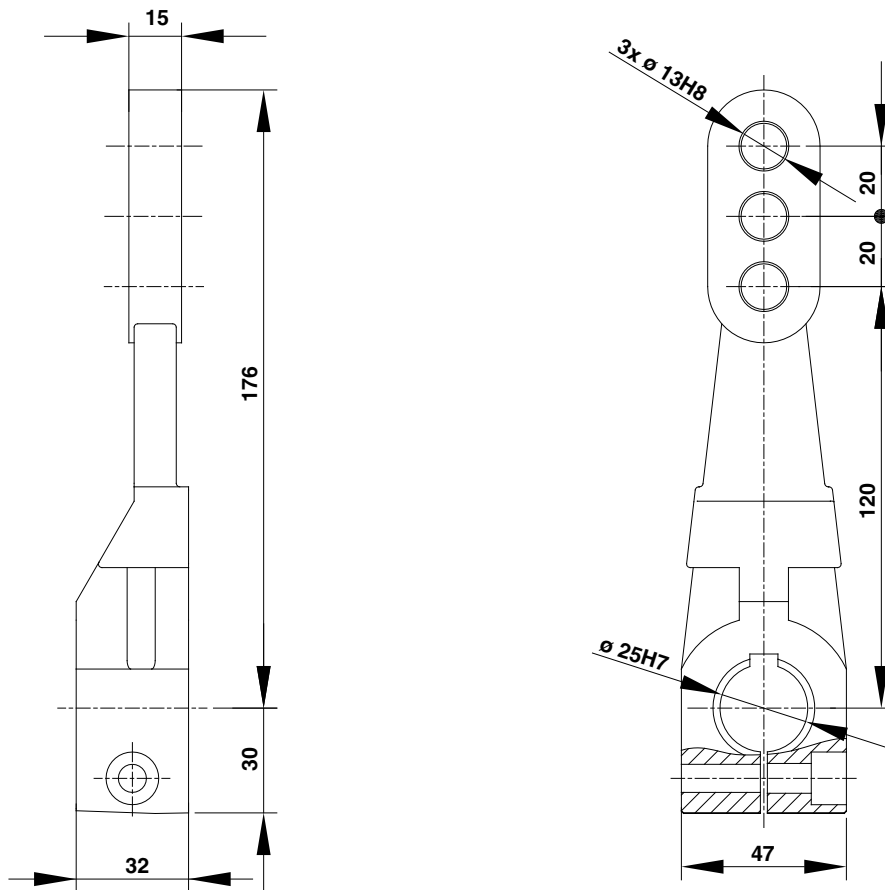

Lever adapter with **Type No. 52 325** actuator

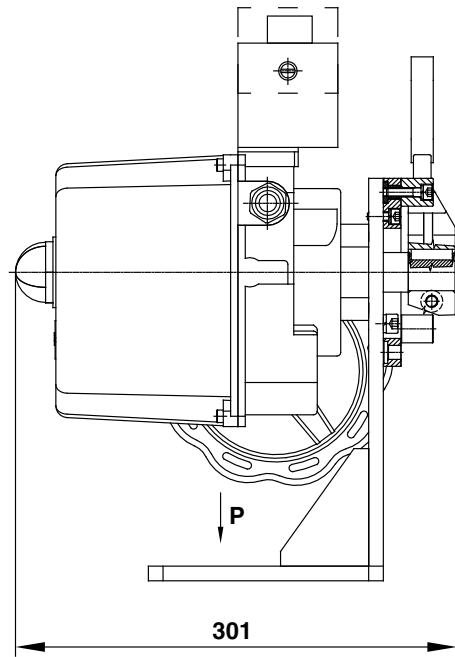
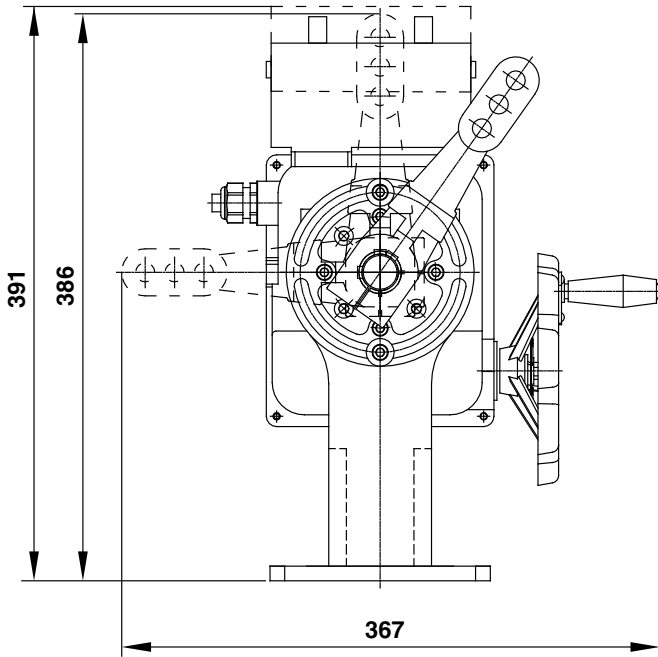

→ P  
M2:1  
(view of the base plate)

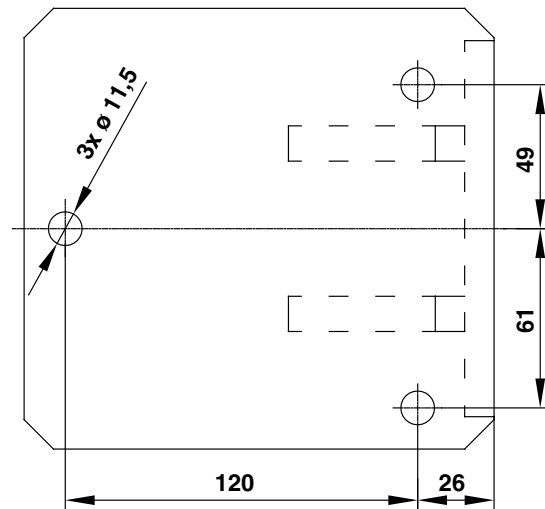

Lever adapter with **Type No. 52 326** actuator

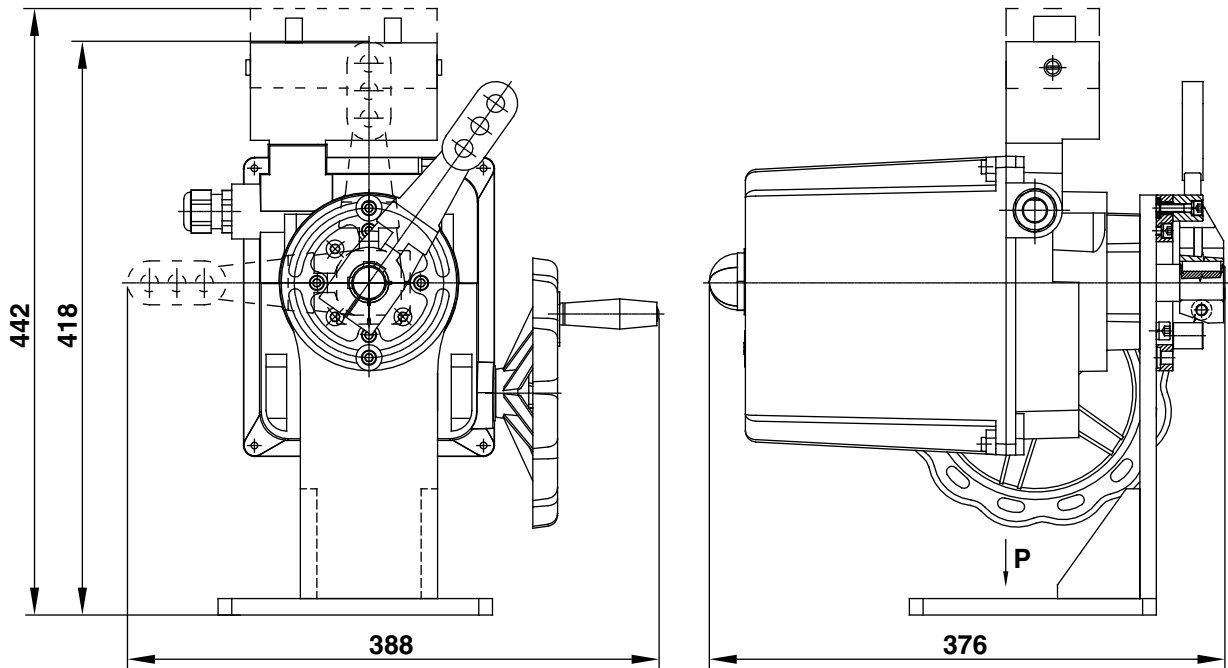

→ P  
**M2:1**  
*(view of the base plate)*

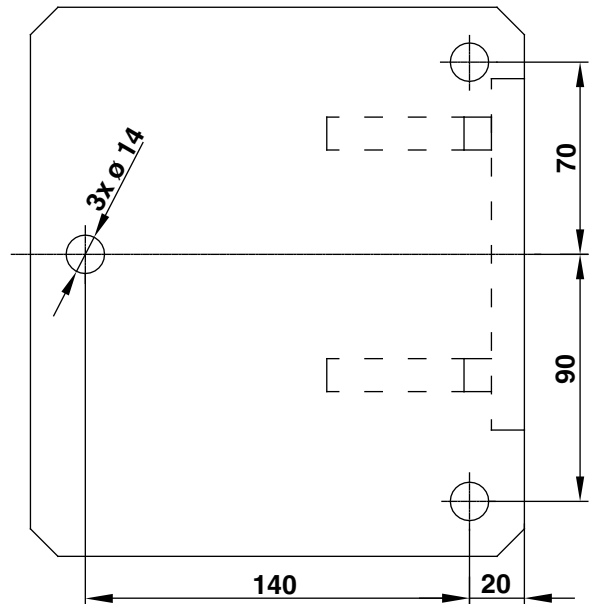

**Note:** Other dimensions are listed in the dimension table.

## Dimensional sketch of **MODACT MOKED** electric actuators

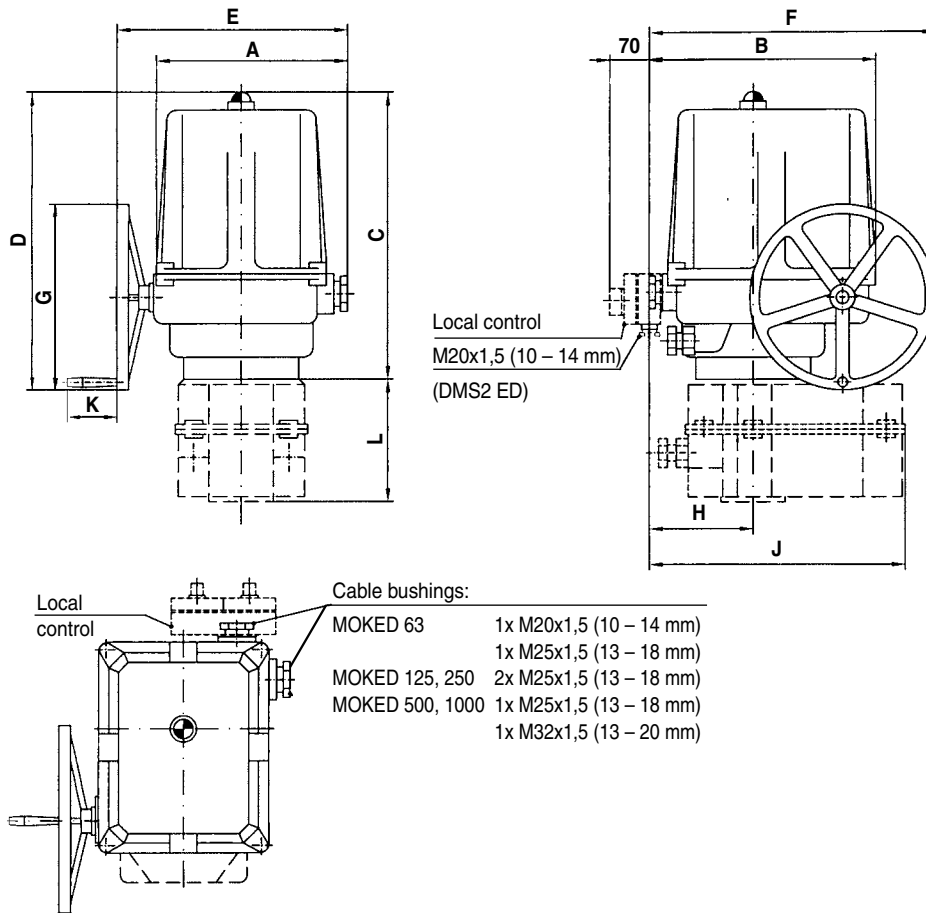

Typ	A	B	C	D	E	F	G	H	J	K	L	Flange
MOKED 63	173	203	247	244	213	245	160	98	-	73	-	F 05, F 04, F 07*
MOKED 125	204	237	325	347	252	290	200	111	-	73	-	F 07, F 05, F 10*
MOKED 250	204	237	325	347	252	290	200	111	263	73	128	F 10, F 07
MOKED 500	250	290	386	398	325	362	250	128	-	73	-	F 12, F 10
MOKED 1000	250	290	386	398	325	362	250	128	323	73	155	F 12

\*) on request

**Note:** Connecting of actuators with connector – on special request.

## Connection dimensions of MODACT MOKED actuators

– for valves and control devices with spindles that are provided with a tight-fit keyway

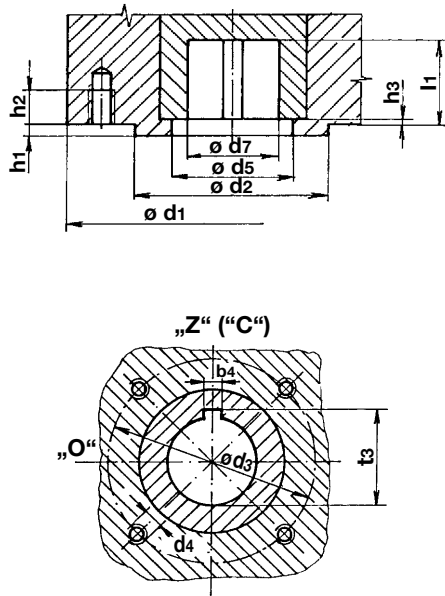

Position of the keyway, according to ISO 5211 and DIN 3337  
(The groove is in the CLOSE position whereas the OPEN position is on the left side when viewing the local position indicator)

Flange	$\varnothing d_1$	$\varnothing d_2$ f8	$\varnothing d_3$	$d_4$	$\varnothing d_7$ H9	$h_{3max}$	$h_{2min}$	$h_{1max}$	$l_{1min}$	$b_4$ Js9	$t_3^{+0,4/+0,2}$	$\varnothing d_5$
F04	65	30	42	M6	18	3	12	3	26	6	20,5	25
F05	65	35	50	M6	22	3	12	3	30	6	24,5	28
F07	90	55	70	M8	28	3	13	3	35	8	30,9	40
F10	125	70	102	M10	42	3	16	3	45	12	45,1	50
F12	150	85	125	M12	50	3	20	3	53	14	53,5	70

**Note:** The CLOSE position "Z" ("C") of the keyway is identical to the "Z" "C" position on the local position indicator.  
Dimension  $d_1$  is determined by a larger flange used by the actuator.

– for valves and control devices with spindles that are provided with a square hole

Position of the square hole in the end position of the actuator. The OPEN position is on the left of the CLOSE position, when viewing the local position indicator. The square hole corresponds to DIN 79. The connecting dimensions comply with DIN 3337 or ISO 5211.

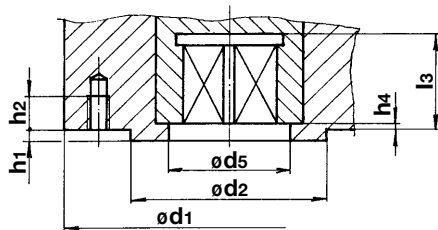

Flange	$\varnothing d_1$	$\varnothing d_2$ f8	$\varnothing d_3$	$d_4$	$h_4$		$h_{2min}$	$h_{1max}$	$l_{3min}$	$s$ H11	$e_{min}$	$\varnothing d_5$
					max	min						
F04	55	30	42	M6	1,5	0,5	12	3	15,1 16,1	11 12	14,1 16,1	25
F05	65	35	50	M6	3	0,5	12	3	19,1 22,1	14 16	18,1 21,2	28
F07	90	55	70	M8	3	0,5	13	3	23,1 26,1	17 19	22,2 25,2	40
F10	125	70	102	M10	3	1	16	3	30,1 33,1 37,1	22 24 27	28,2 32,2 36,2	50
F12	150	85	125	M12	3	1	20	3	37,1 44,1	27 32	36,2 42,2	70

**Note:** The CLOSE position "Z" ("C") of the square hole for the spindle is identical to the "Z" "C" position on the local position indicator.  
Dimension  $d_1$  is determined by a larger flange used by the actuator.

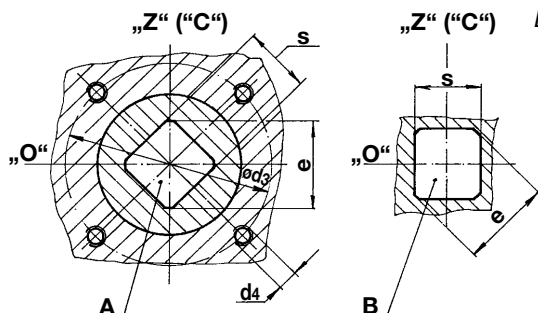

A – Square-end joint in the basic position

B – Square-end joint positioned at an angle of 45°



## 8. ASSEMBLY AND PUTTING ACTUATOR INTO OPERATION

After unpacking the actuator, inspect and check it for possible visible damage during transportation or storage. If no visible defect was detected connect the actuator to external control and feeding circuits. By short starting of the actuator in an intermediate position of working stroke, make sure that the actuator output shaft rotates in correct direction. For the electronics DMS2 ED in version CONTROL and electronics DMS2 the sense of rotation is electronically guarded.

In case of actuators with single-phase electric motor, the sense of rotation of the output shaft is changed by interchanging inlet phase conductors to the electric motor.

In case of actuators with three-phase electric motor, interchange any two conductors of terminals U, V, W of the actuator terminal board. Then, repeat functional check. After securing correct electric connection of the actuator, fit it to the valve and adjust, either manually or with a connected computer, according to particular part of these instructions.

### ***Important warning!***

- 1) In carrying-out adjustment, repair, and/or maintenance, secure the actuator in a prescribed way to prevent its connection to supply mains and, thus, a possibility of injury by electric shock or rotating gear wheels.
- 2) In reversing run of the actuators with single-phase electric motor, phase must not be present on both outlets of the starting capacitor, not even for a moment; otherwise, the capacitor can be discharged via contacts of torque limit switches that can be baked together.
- 3) When the thermal protection built-in in the electric motor is activated it should be considered that the actuator can start automatically after winding of the electric motor has cooled down – in case that there is supply voltage present on the electric motor terminals.

After adjusting the actuator, check its function. In particular, check whether the actuator starts correctly. If this is not the case switch off power supply to the actuator immediately to prevent damaging the electric motor and find out the defect.

## 9. OPERATION AND MAINTENANCE OF ACTUATORS

The actuators can be controlled both remotely electrically and manually from their installation site. The manual control is realized by a hand wheel of the actuator; it requires no change-over switch and can be used without any danger to the operator even in case the electric motor is running.

Maintenance of the actuators consists in possible replacement of defective parts and adjustment of the electromagnetic brake of electric motors fitted with this brake. The brake should be adjusted after  $0.5 \times 10^5$  closing operations. The air gap between the armature and the core of the brake electromagnet is adjusted to the value 0.6 – 0.8 mm. The adjustment is performed by means of nuts on the brake pull rod. Use the nut closer to the electric motor to adjust size of the air gap; the other nut is securing. After adjustment, check correct function of the brake and secure the nuts with drops of paint. The grease filling is stable for the actuator life time, i.e. at least 6 years. If the actuator is capable of operation even after 6 years old grease should be removed from the power part and replaced with new one.

Once in two years, it is recommended to lightly smear the driving wheel gearing on the output shaft and the gear wheel of the position sensor in the control box. Use the lubricant CIATIM 201 or PM MOGUL LU 2-3.

Within 6 months at the latest after putting the actuator into operation and then at least once a year, connecting bolts between the valve and the actuator should be tightened in a cross-wise manner.

## Spare parts

Name	Stock no.	Type	Using
Sealing	223535600	52 325	between cover of control part and power part box
Sealing	23353482	52 326,7	between cover of control part and power part box
Sealing	23252488	52 328,9	between cover of control part and power part box
Source board DMS2.ED.ZT	2339620300	DMS2.ED	
Position sensor DMS2.ED.ST90	2339620303	DMS2.ED	
Torque sensor DMS2.TORK	2339620003		common for DMS2.ED and DMS2
Analog module DMS2.ED.CPTT	2339620304	DMS2.ED	
Board of power relays DMS2.FIN	2339620031	52 328,9	common for DMS2.ED and DMS2, just for 3-phase
Relay Finder 62.33.8.230.0040	2334513109	52 328,9	common for DMS2.ED and DMS2, just for 3-phase
Relay Finder 56.34.8.230.0000	2340553603	52 325-7	common for DMS2.ED and DMS2, just for 3-phase
Cable sensor-torque K.TORK	214654764PRO		common for DMS2.ED and DMS2
Cable sensor-source board K.ZED2	214657890PRO	DMS2.ED	
Cable sensor-analog module K.AED2	214654767PRO	DMS2.ED	
Cable sensor - COM K.COM	214654795PRO		common for DMS2.ED and DMS2
Display DMS2.ED.DT	2339620305	DMS2.ED	
Cable sensor-display K.DED2	214654766PRO	DMS2.ED	
Cable display - COM K.COMED2	214654797PRO	DMS2.ED	
Source board DMS2.ZD2	2339620024	DMS2	analog and profibus
Board analog DMS2.A22	2339620042	DMS2	analog
Board profibus DMS2.PR2	2339620026	DMS2	profibus
Position sensor DMS2.S90	2339620039	DMS2	analog and profibus
Display DMS2.DP	2339620018	DMS2	analog and profibus
Board of local control DMS2.H2	2339620030	DMS2	analog and profibus
Cable source - sensor K.ZDR2	214654801PRO	DMS2	analog and profibus
Cable display - control K.H2	214654802PRO	DMS2	analog and profibus
Cable source - analog/profibus K.ZA	214654803PRO	DMS2	analog and profibus
Cable analog/profibus - displej K.D2	214654804PRO	DMS2	analog and profibus
Cable sensor - analog K.SA2	214654805PRO	DMS2	analog

*A setting program is available for the actuators (it is described in these Assembly Instructions); it enables the parameters of the electronic outfit of the actuators to be set and checked by a computer.*

*In case the computer is not fitted with a serial port the converter USB-RS 232, can be ordered.*



Development, production and services of electric actuators and switchboards.  
Top-quality sheet-metal processing (TRUMPF equipment), powder paint shop.

## SURVEY OF PRODUCED ACTUATORS

### **KP MINI, KP MIDI**

Electric rotary (90°) actuators (up to 30 Nm)

### **MODACT MOK, MOKED, MOKP Ex, MOKPED Ex**

Electric rotary (90°) actuators for ball valves and flaps

### **MODACT MOKA**

Electric rotary (90°) actuators for nuclear power stations  
application outside containment

### **MODACT MON, MOP, MONJ, MONED, MOPED, MONEDJ**

Electric rotary multi-turn actuators

### **MODACT MO EEx, MOED EEx**

Explosion proof electric multi-turn actuators

### **MODACT MOA**

Electric multi-turn actuators for nuclear power stations  
application outside containment

### **MODACT MOA OC**

Electric multi-turn actuators for nuclear power stations  
application inside containment

### **MODACT MPR Variant**

Electric rotary (160°) lever actuators with a variable output speed

### **MODACT MPS, MPSP, MPSED, MPSPED**

Electric rotary (160°) lever actuators with a constant output speed

### **MODACT MTN, MTP, MTNED, MTPED**

Electric linear thrust actuators with a constant output speed

---

Deliveries of assembled actuator + valve (or MASTERGEAR gearbox) combinations

---

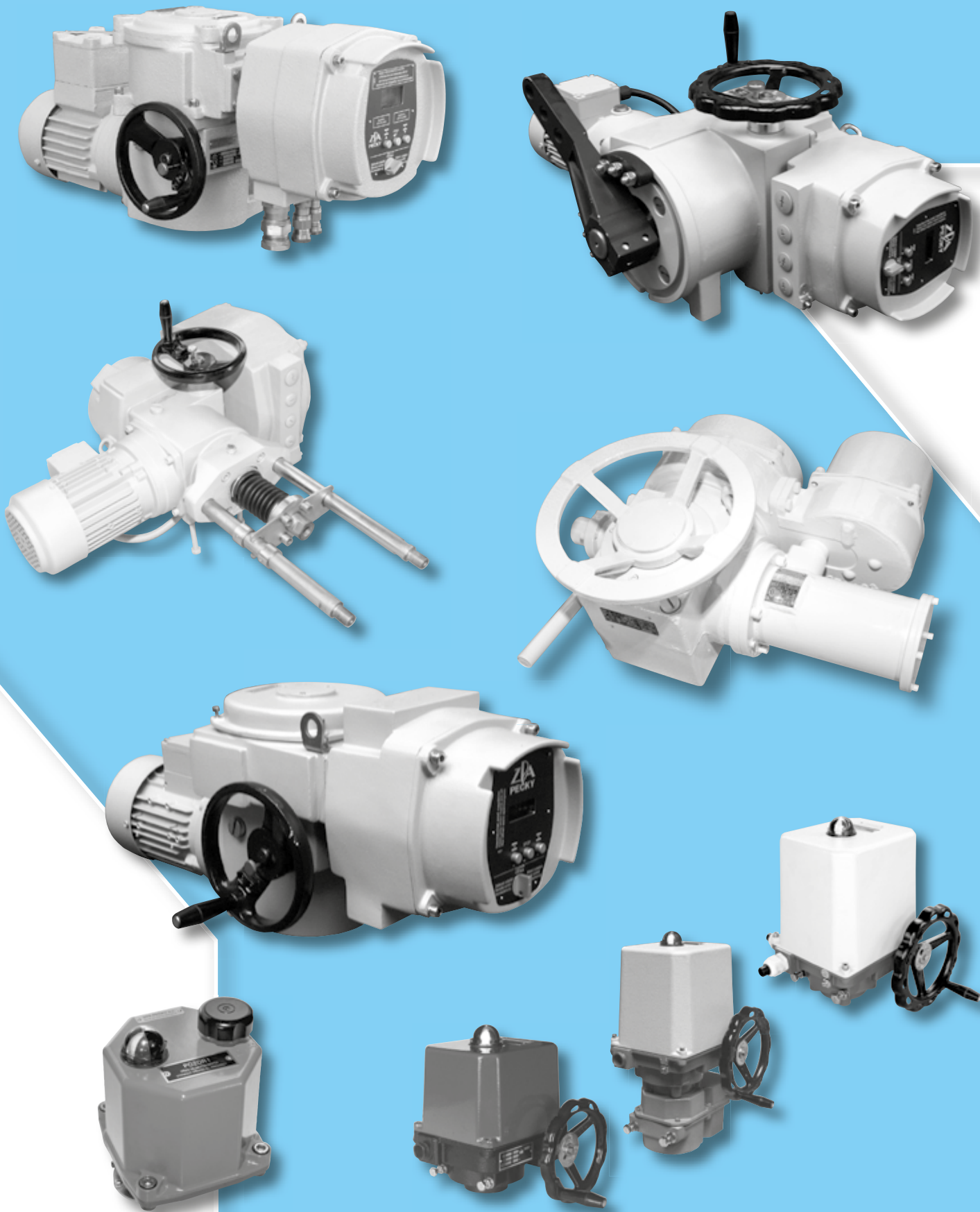

ZPA Pečky, a.s.  
tř. 5. května 166  
289 11 PEČKY, Czech Republic  
[www.zpa-pecky.cz](http://www.zpa-pecky.cz)

tel.: +420 321 785 141-9  
fax: +420 321 785 165  
+420 321 785 167  
e-mail: [zpa@zpa-pecky.cz](mailto:zpa@zpa-pecky.cz)