



**Electric multi-revolution actuator  
for nuclear power plants  
inside containment**

**MODACT MOA OC**

**Type numbers 52 079**



[www.zpa-pecky.cz](http://www.zpa-pecky.cz)

ZPA Pečky, a.s. is certified company in accordance with ISO 9001 as amended.

## APPLICATION

The electric rotary multi-revolution actuators are designed for remote control of special shut-off valves installed under the containment with reactors VVER or in hermetic boxes of nuclear power plants with reactors RBMK. The electric actuators enable direct connection to the valves or connection by means of elements of remote control.

The electric actuators are used for controlling sliding valves and valves fitted with spindle nut. The electric actuators comply with the document Interatomenergo „OTT-87 „Valves for installations and piping of nuclear power plants - general technical requirements.

### Technical requirements

The electric actuators are fed with alternating current of frequency 50 Hz, three-phase voltage 400 / 230 or 380 / 220 V.

### Protective enclosure

Type of protective enclosure of the actuator is IP 67, according to ČSN EN 60529.

### Service life of electric actuator

According to these TP, service life of the electric actuators is min. 20 years; during their assembly, operation and maintenance, the manufacturer's instructions should be followed, working conditions according to point 2.4 of Technical conditions observed and worn-out or damaged parts replaced, however, not sooner than after 10,000 hours of continuous operation.

### Working position

Working position of the actuators is arbitrary.

### Working regime - frequency of switching

The longest working cycle (close-open-close) is 10 minutes with the ratio of run to idle time 1:3 (load factor 25 %). Average loading of the electric actuator during the running time is 33 % of the value of maximum tripping torque and it is called rated torque.

Maximum number of cycles per hour is 6 (12 closings and openings) with the ratio of run to idle time 1:3.

## DESCRIPTION

The actuators are delivered with asynchronous electric motors with short-circuit armature and alternating three-phase feeding voltage 400 (380) V, frequency 50 Hz.

### Operating conditions

Normal working regime

Temperature	from 5 to 70°C
Pressure	from 0.085 to 0.1032 MPa (with the nuclear power plant located at the altitude 1 000 m .s. l.)
Relative humidity	up to 95 +3 %
Level of radiation	up to 1 Gy / h

### Working regime during failure in heat removal - reactors VVER:

Temperature	from 5°C to 75°C
Pressure	0.05 - 0.12 MPa
Relative humidity	do 100%
Level of radiation	up to 1 Gy / h
Periode of regime duration	up to 15 h
Frequency of regime occurrence	once a year

### Resistance against effect of radioactive gamma radiation

The electric actuators must work reliably until they receive the integral dose of gamma radiation  $1 \times 10^6$  Gy (1 Gy = 100 rad).

## **Resistance against seismic shocks**

The actuators must be resistant against shocks of acceleration 8 g in any direction, in the range of actuating frequencies 20 to 50 Hz for the period of up to 20 s. Moreover, seismic resonance tests must be carried out in the frequency range of 5 to 20 Hz.

## **Manual control**

The actuators are fitted with manual control realized by the hand wheel directly (without a clutch); it is possible even when the electric motor is running. By rotating the hand wheel in the clockwise direction the output shaft of the actuators also rotates in the clockwise direction (viewing the shaft in the control box). Assuming the left thread of the valve nut, the actuator closes the valve.

**Table 1 – Basic technical parameters and characteristics of actuator, type MODACT MOA OC for shut-off vales installed under containment of nuclear power plants with reactors VVER or RBMK**

Size of connecting flange		ACTUATOR										ELECTRIC MOTOR									
		Type designation	Type number		Range of setting torque tripping [Nm]	Range of setting output revolutions (of stroke) [rev.]	Speed of output shaft resetting / electric motor [min <sup>-1</sup> ]	Gear ratio output shaft / electric motor	Gear ratio output shaft / hand wheel	Max. force on hand wheel [N] <sup>1)</sup>	Min. guaranteed torque at U=80% U <sub>nom</sub> [Nm] <sup>3)</sup>	Weight of actuator incl. electric motor [kg]	Type	Output [kW]	Speed of electric motor [min <sup>-1</sup> ]	Rated current [A]	Engagement current [A]	Efficiency [%]	Power factor [cos φ]	Ratio of engagement torque / rated torque	Ratio of engagement current / rated current
F10 (F07)	MOA OC 30-9	52 079 . x x 1 0			9	1:155			43	17,5	1AJSI 89K-4	0,03	1465	0,37	1,2	33,8	0,37	2,5	3,2	0,5	3,8
	MOA OC 30-15	52 079 . x x 2 0			15	1:91		4	41	18	1AJSI 89A-4	0,055	1455	0,45	1,6	45,6	0,41	2,2	3,6	0,8	4,2
	MOA OC 30-25	52 079 . x x 3 0	10 – 30	1,5 – 38	25	1:54	1:93		60	18,5	1AJSI 89B-4	0,12	1420	0,7	2,5	54,2	0,52	2,4	3,6	2	4,8
	MOA OC 30-40	52 079 . x x 4 0			40	1:34			59	19,5	1AJSI 89D-4	0,30	1342	1,1	3,7	60,7	0,63	1,4	3,3	3	5,7

1) The table shows one force from pair of forces acting at diameter of the hand wheel.

2) The cables are connected through a gland bushing.

3) The actuator mass tolerance is ± 5%.

**Meaning of complementary numbers in the actuator type number:**

- the first complementary number means the way of mechanical connection:  
 1xxx - connection F07, shape C  
 2xxx - connection F07, shape D  
 3xxx - connection F07, shape E  
 4xxx - connection F10, shape C  
 5xxx - connection F10, shape D  
 6xxx - connection F10, shape E

- the second complementary number means the required time of torque blocking:

- x0xx - time of blocking between 1.5 and 3 revolutions of output shaft after reversing
- x1xx - time of blocking between 0.75 and 1.5 revolutions of output shaft after reversing
- x2xx - time of blocking between 0.4 and 0.75 revolutions of output shaft after reversing

- the third complementary number means resetting speed – see the table.

- the fourth complementary number means possible use of position transmitter: 0

Dimensional sketch of actuator **MODACT MOA OC**, Type No. 52 079

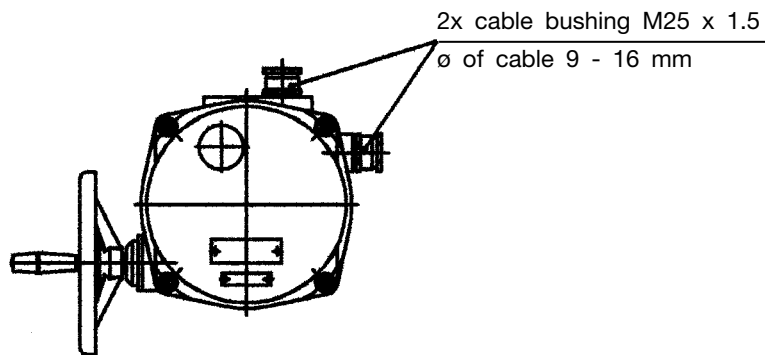
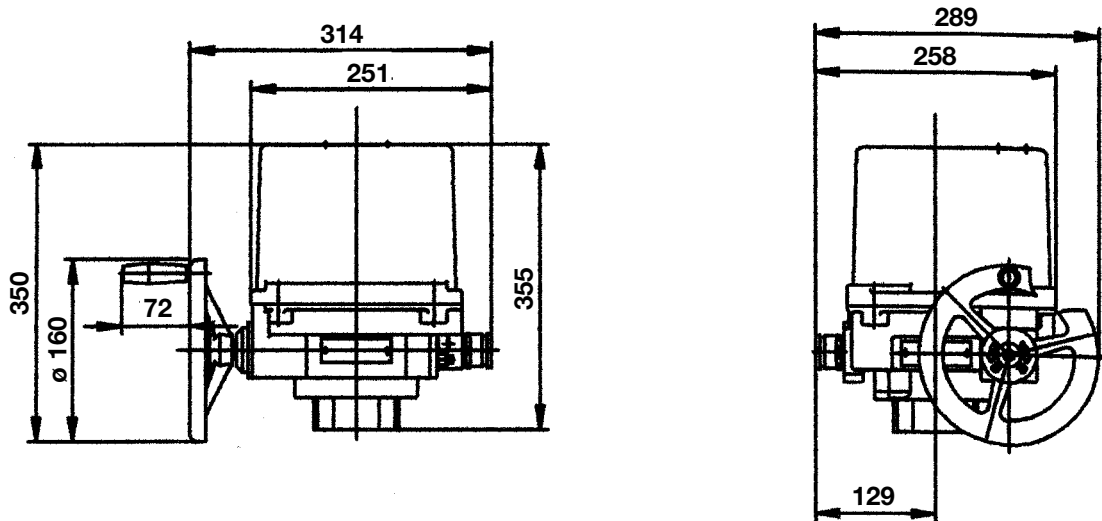

Centre of mass of actuator **MODACT MOA OC**, Type No. 52 079

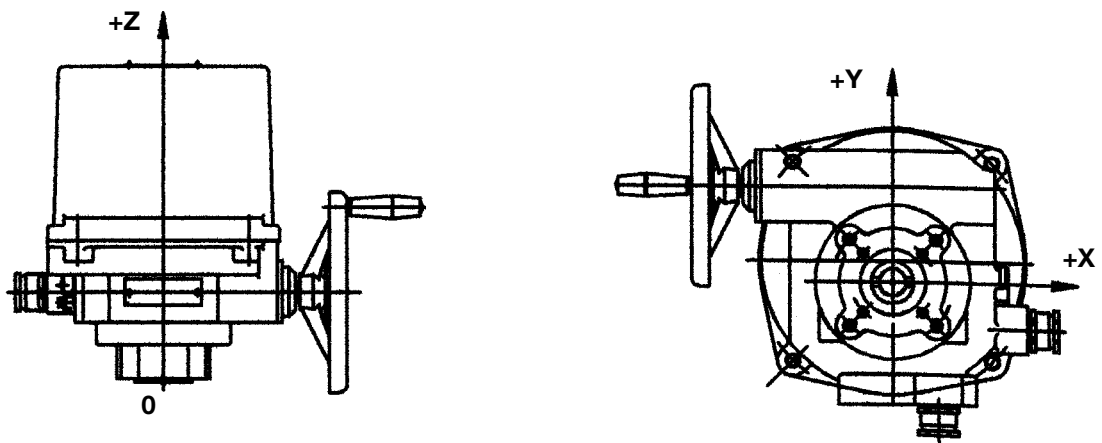

Type number	Coordinates of centre of mass			Actuator weight (kg)
	x (mm)	y (mm)	z (mm)	
52079.xx10	-1,5	+24,5	+158,5	17,5
52079.xx20	-1,5	+24,5	+160	18
52079.xx30	-1,5	+24,5	+162	18,5
52079.xx40	-1,5	+24,5	+164	19,5

Mechanical connecting dimensions of actuator **MODACT MOA OC**, Type No. 52 079

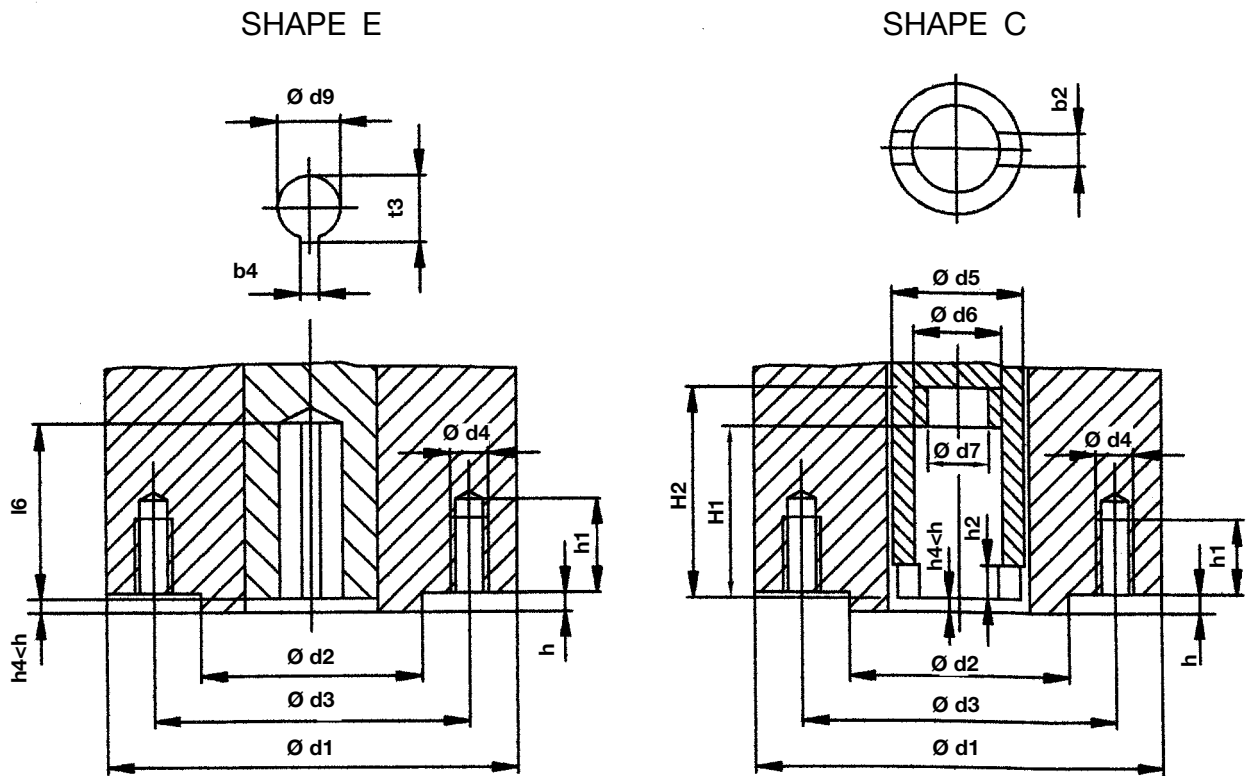

Flange size	Common data for both shapes							Data for shape C							Data for shape E			
	Ø d1	Ø d2f8	Ø d3	Ø d4	Number of threaded holes	h1	h	Ø d5	h2	H1	H2	b2H11	Ø d8	Ø d7	Ø d9 H8	l6	t3	b4Js9
F 07	125	55	70	M8	4	16	3	40	10	75	120	14	28	22	16	40	18,1	5
F 10	125	70	102	M10	4	20	3	40	10	75	120	14	28	22	20	55	22,5	6

Diagram of internal electric wiring of actuators **MODACT MOA OC**, Type No. 52 079

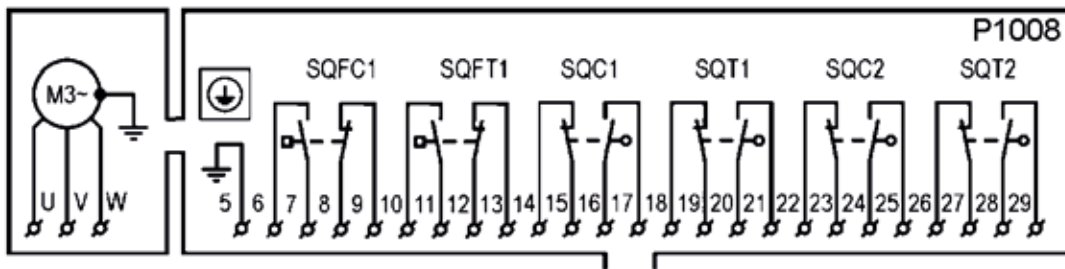

**LEGEND:**

- SQFC1 - torque-limit switch „open“
- SQFT1 - torque-limit switch „close“
- SQC1 - position-limit switch „open“
- SQT1 - position-limit switch „close“
- SQC2 - position signalling switch „open“
- SQT2 - position signalling switch „close“
- M - three-phase asynchronous motor

*The contacts of micro-switches are drawn in the intermediate position of the actuator output shaft.*

Operation diagram of torque, position and signalling switches

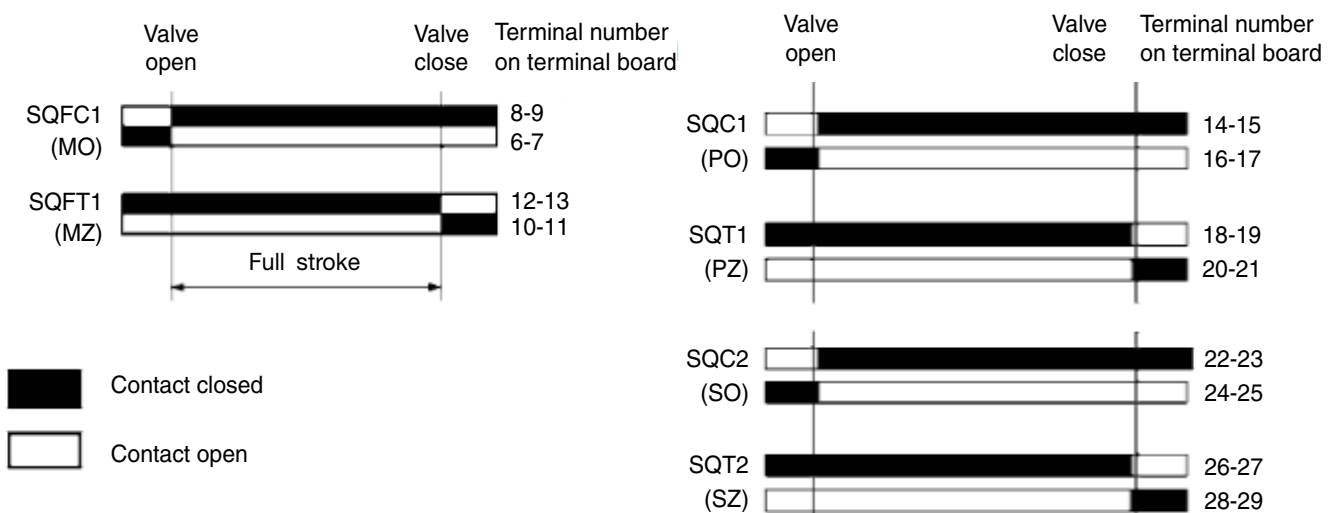



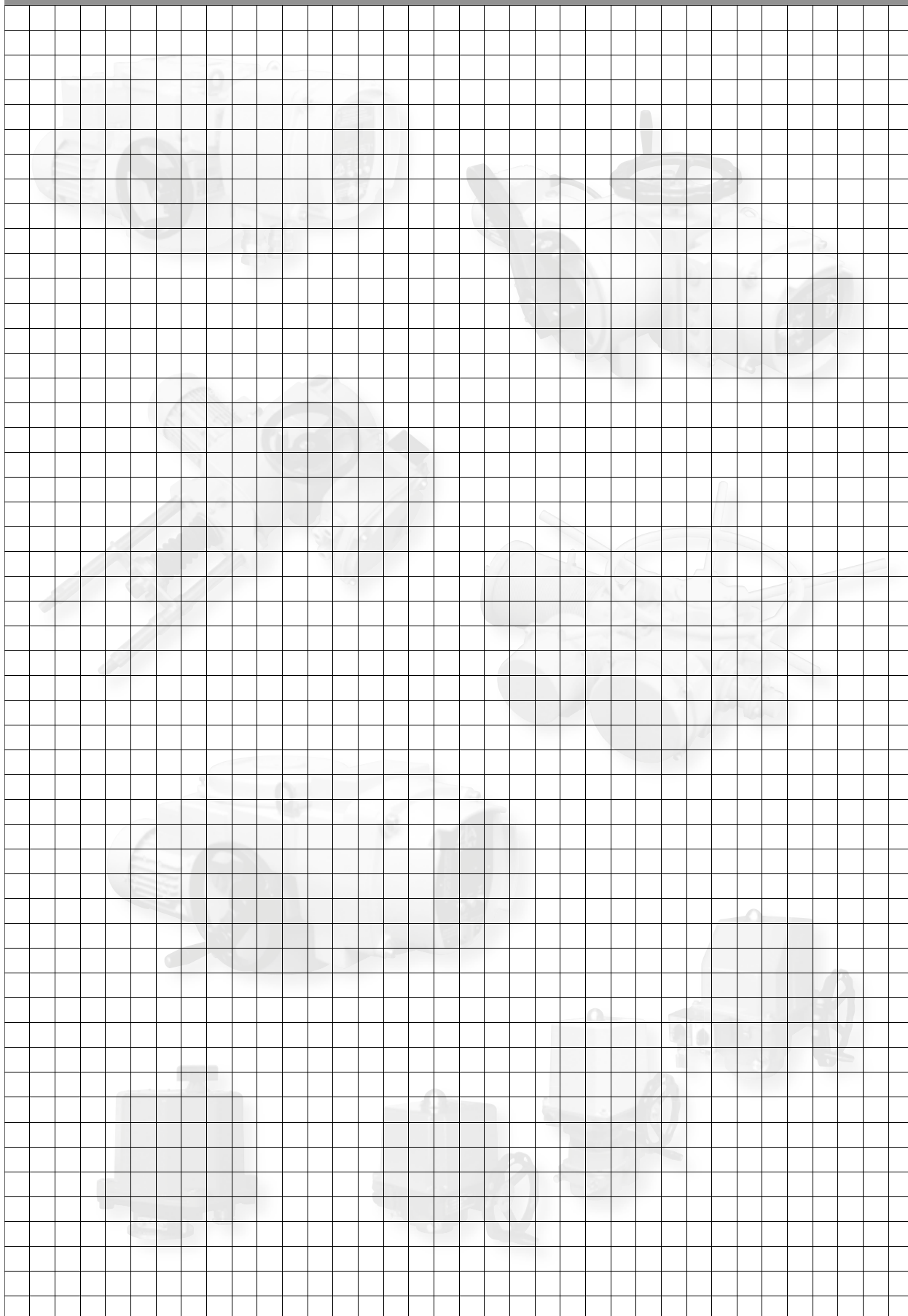

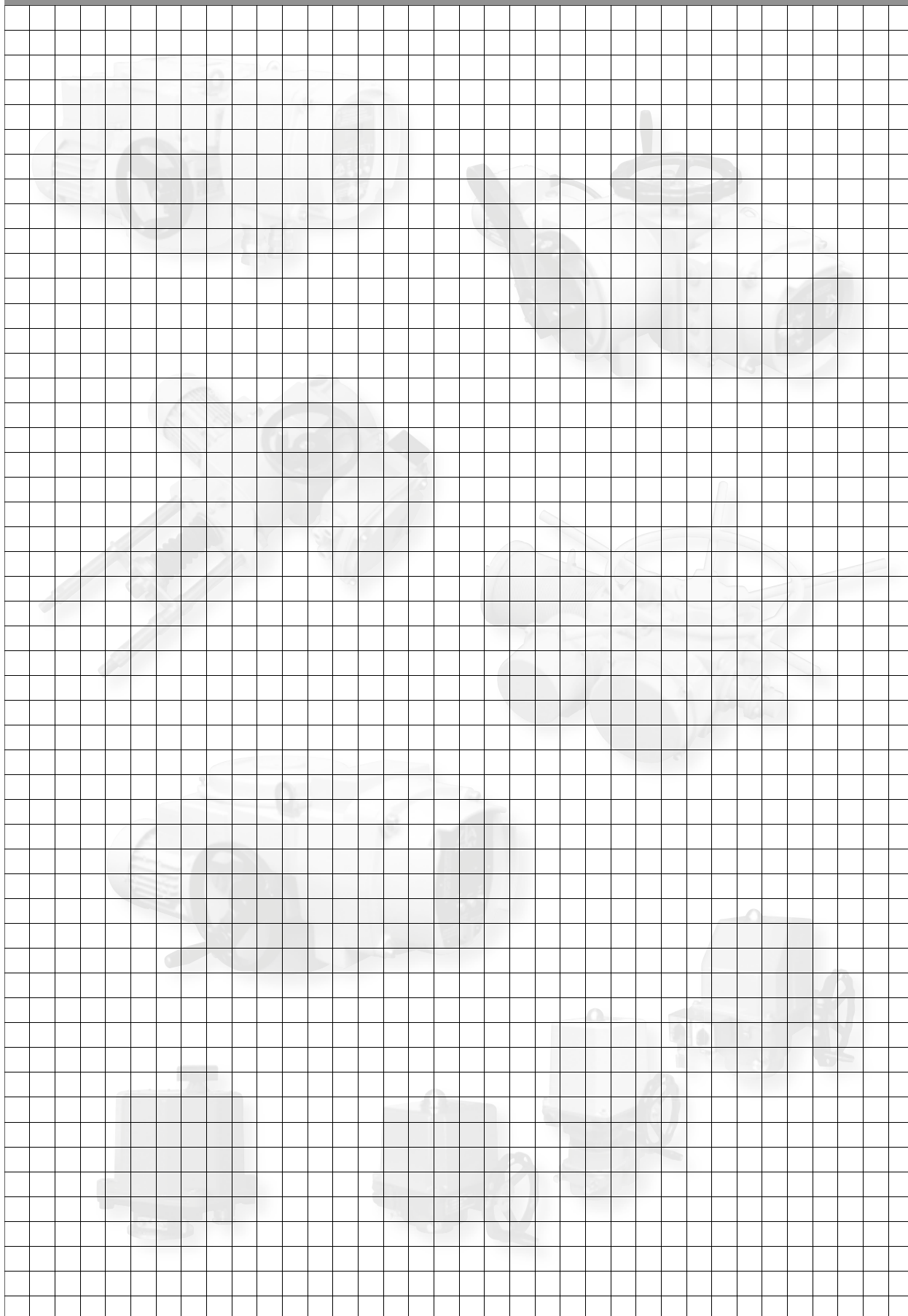



Development, production and services of electric actuators and switchboards.  
Top-quality sheet-metal processing (TRUMPF equipment), powder paint shop.

## SURVEY OF PRODUCED ACTUATORS

### **KP MINI, KP MIDI**

Electric rotary (90°) actuators (up to 30 Nm)

### **MODACT MOK, MOKED, MOKP Ex**

Electric rotary (90°) actuators for ball valves and flaps

### **MODACT MOKA**

Electric rotary (90°) actuators for nuclear power stations application outside containment

### **MODACT MON, MOP, MONJ, MONED, MOPED, MONEDJ**

Electric rotary multi-turn actuators

### **MODACT MO EEX, MOED EEX**

Explosion proof electric multi-turn actuators

### **MODACT MOA**

Electric multi-turn actuators for nuclear power stations application outside containment

### **MODACT MOA OC**

Electric multi-turn actuators for nuclear power stations application inside containment

### **MODACT MPR VARIANT**

Electric rotary (160°) lever actuators with a variable output speed

### **MODACT MPS KONSTANT, MPSED**

Electric rotary (160°) lever actuators with a constant output speed

### **MODACT MTN, MTP, MTNED, MTPED**

Electric linear thrust actuators with a constant output speed

---

Deliveries of assembled actuator + valve (or MASTERGEAR gearbox) combinations

---

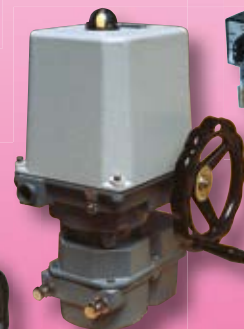
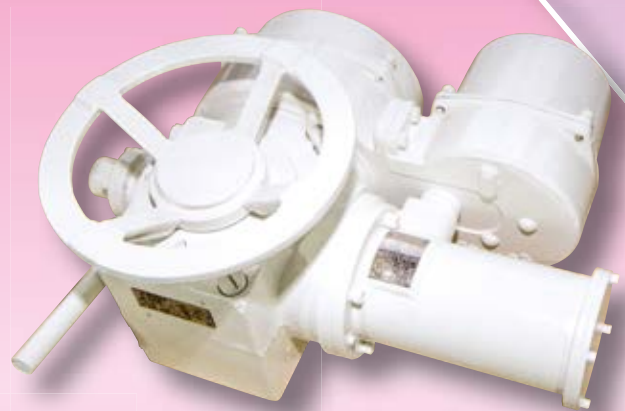
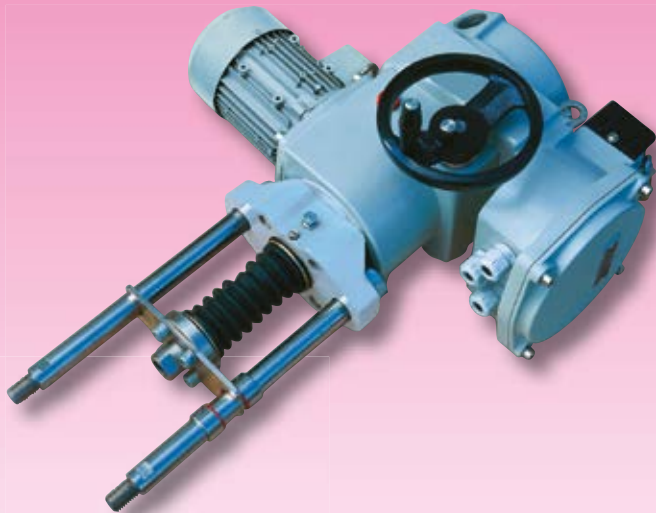

ZPA Pečky, a.s.  
tř. 5. května 166  
289 11 PEČKY, Czech Republic  
[www.zpa-pecky.cz](http://www.zpa-pecky.cz)

tel.: +420 321 785 141-9  
fax: +420 321 785 165  
+420 321 785 167  
e-mail: [zpa@zpa-pecky.cz](mailto:zpa@zpa-pecky.cz)